

BANGLADESH PETROLEUM CORPORATION (BPC)

EXECUTING AGENCY:

EASTERN REFINERY LIMITED (ERL)
NORTH PATENGA, CHATTOGRAM-4204
BANGLADESH

**TENDER DOCUMENT FOR
RENOVATION OF CRUDE OIL STORAGE TANK
NO. T-6101C
(NATIONAL TENDER)**

Invitation for Tender No: ER/DEV (M)-40(1)/2022
Issued on: 07/08/2022



Table of Contents



<u>Section</u>	<u>S u b j e c t</u>	<u>Page</u>
	Invitation to Tenderers	1
	National Tender Notice	2
Section 1	Instruction to Tenderers	3
A. General		3
1	Scope of Tender	3
2	Interpretation	3
3	Source of Funds	3
4	Corrupt, Fraudulent, Collusive, Coercive (or Obstructive in case of Development Partner) Practices	3-5
5	Eligible Tenderers	5-6
B. Tender Document		6
6	Eligible Materials, Equipment and Associated Services	6
7	Site Visit	6
8	Tender Document: General	6-7
9	Clarification of Tender Document	7
10	Pre-Tender Meeting	7
11	Addendum to Tender Document	7-8
C. Qualification Criteria		8
12	General Criteria	8
13	Litigation History	8
14	Experience Criteria	8
15	Financial Criteria	9
16	Personnel Capacity	9
17	Equipment Capacity	9
18	Joint Venture (JV)	9
19	Subcontractor(s)	9-10
D. Tender Preparation		10
20	Only One Tender	10
21	Cost of Tendering	10
22	Issuance and Sale of Tender Document	10
23	Language of Tender	10
24	Contents of Tender	10-11
25	Tender Submission Letter and Bill of Quantities	11
26	Alternatives	11-12
27	Tender Prices, Discounts and Price Adjustment	12
28	Tender Currency	12
29	Documents Establishing Eligibility of the Tenderer	12-13



30	Documents Establishing the Eligibility and Conformity of Materials, Equipment and Services	13
31	Documents Establishing Technical Proposal	13
32	Documents Establishing the Tenderer's Qualification	13-14
33	Validity Period of Tender	14
34	Extension of Tender Validity and Tender Security	14
35	Tender Security	14
36	Form of Tender Security	14-15
37	Authenticity of Tender Security	15
38	Return of Tender Security	15
39	Forfeiture of Tender Security	15
40	Format and Signing of Tender	15-16
E. Tender Submission		16
41	Sealing & Marking of Tender	16-17
42	Deadline for Substitution of Tender	17
43	Late tender	17
44	Modification, Substitution or Withdrawal of Tender	17
45	Tender Modification	17
46	Tender Substitution	17-18
47	Tender Withdrawal	18
F. Tender Opening and Evaluation		18
48	Tender Opening	18-19
49	Evaluation of Tenders	19
50	Evaluation Process	19-20
51	Preliminary Examination	20
52	Technical Responsiveness and Technical Evaluation	20-21
53	Clarification on Technical Offer	21
54	Restrictions on Disclosure of Information	21
55	Approval of Technical Offer	21
56	Financial Offer Opening	21-22
57	Clarification on Financial Offer	22
58	Correction of Arithmetical Errors	23
59	Financial Evaluation	23-24
60	Price Comparison	24
61	Negotiations	24
62	Post-qualification	24
63	Procuring Entity's Right to Accept any or to Reject Any or All Tenders	25
64	Rejection of All Tenders	25
65	Informing Reasons for Rejection	25
G. Contract Award		25
66	Award Criteria	25



67	Notification of Award	25-26
68	Performance Security	26
69	Form and Time Limit for Furnishing of Performance Security	26
70	Validity of Performance Security	26
71	Authenticity of Performance Security	26
72	Contract Signing	26
73	Publication of Notification of Award of Contract	27
74	Debriefing of Tenderers	27
75	Adjudicator	27
76	Right to Complain	27
Section 2.	Tender Data Sheet	28
A	General	28
B	Tender Document	28
C	Qualification Criteria	28-31
D	Tender Preparation	31-32
E	Tender Submission	32-33
F	Tender Opening and Evaluation	33
G	Contract Award	33
Section 3.	General Conditions of Contract	34
A. General		34
1	Definitions	34-37
2	Interpretation	37-38
3	Communications & Notices	38
4	Governing Law	38
5	Governing Language	38
6	Documents forming the Contract and Priority of Documents	38
7	Scope of Works	38
8	Assignment	38
9	Eligibility	38-39
10	Gratuities/ Agency Fees	39
11	Confidential Details	39
12	Joint Venture (JV)	39
13	Possession of the Site	40
14	Access to the Site	40
15	Procuring Entity's Responsibilities	40
16	Approval of the Contractor's Temporary Works	40
17	Contractor's Responsibilities	40
18	Taxes and Duties	40
19	Contractor's Personnel	40
20	Subcontracting	40-41
21	Other Contractors	41
22	Project Manager's Decisions	41



23	Delegation	41
24	Instructions	41
25	Queries About the Contract Conditions	41
26	Safety, Security and Protection of the Environment	41
27	Working Hours	41
28	Welfare of Labourers	41-42
29	Child Labour	42
30	Discoveries	42
31	Procuring Entity's and Contractor's Risks	42
32	Procuring Entity's Risks	42
33	Contractor's Risks	42
34	Copyright	43
35	Limitation of Liability	43
36	Insurance	43
37	Management and Progress Meetings	43-44
38	Corrupt, Fraudulent, Collusive or Coercive Practices	44-45
B. Time Control		44
39	Commencement of Works	45
40	Completion of Works	45
41	Programme of Works	46
42	Pro-rata Progress	46
43	Early Warning	46
44	Extension of the Intended Completion Date	46-47
45	Delays Caused by Authorities	47
46	Acceleration	47
47	Delays Ordered by the Project Manager	47
48	Suspension of Work	47
49	Consequences of Suspension	48
C. Quality Control		48
50	Execution of Works	48
51	Examination of Works before covering up	48
52	Identifying Defects	48
53	Testing	48
54	Rejection of Works	48
55	Remedial Work	49
56	Correction of Defects	49
57	Uncorrected Defects	49
D. Cost Control		49
58	Contract Price	49
59	Bill of Quantities (BOQ)	49
60	Changes in the Quantities and Unit Rate	49-50
61	Issue of Variation or Extra Work Order	50



62	Costing of Variation Orders or Extra Work Orders	50-51
63	Cash Flow Forecasts	51
64	Payment Certificates	51
65	Payments to the Contractor	51-52
66	Delayed Payment	52
67	Compensation Events	52-53
68	Adjustments for Changes in Legislation	53
69	Price Adjustment	53-54
70	Retention Money	54
71	Liquidated Damages	54
72	Bonus	54
73	Advance Payment	54-55
74	Performance Security	55
75	Provisional Sums	55
76	Dayworks	56
77	Cost of Repairs to Loss or Damages	56
E. Completion of Contract		56
78	Completion	56
79	Taking Over	56
80	Amendment of Contract	56
81	Final Account	56
82	As-built Drawings and Manuals	56
83	Force Majeure	57
84	Notice of Force Majeure	57
85	Consequences of Force Majeure	57
86	Release from Performance	58
F. Termination		58
87	Termination	58-59
88	Payment upon Termination	59-60
89	Property	60
90	Frustration	60
G. Claims, Disputes and Settlements		60
91	Contractor's Claims	60-61
92	Settlement of Disputes	61
Section 4.	Particular Conditions of Contract	62-65
	Additional Conditions of Contract	66-67
	Appendix to the Tender	68-69
Section 5.	Tender and Contract Forms	70
	Technical Offer Submission Letter (Form PW3A-1a)	71-73
	Financial Offer Submission Letter (Form PW3A-1b)	74-76
	Tenderer Information (Form PW3A-2)	77-79
	JV Partner Information (Form PW3A-3)	80-82



	Subcontractor Information (Form PW3A-4)	83-84
	Personnel Information (Form PW3A-5)	85
	Bank Guarantee for Tender Security (Form PW3A-6)	86
	Letter of Commitment for Bank's Undertaking for Line of Credit (Form PW3A-7)	87
	Notification of Award (Form PW3A-8)	88
	Contract Agreement (Form PW3A-9)	89
	Bank Guarantee for Performance Security (Form PW3A-10)	90
	Bank Guarantee for Advance Payment (Form PW3A-11)	91
	Bank Guarantee for Retention Money Security (Form PW3A-12)	92
Section 6.	Bill of Quantities	93-105
Section 7.	General Specifications	106-107
Section 8.	Particular Specifications	108-110
Section 9.	List of Drawings	111
Format	Commencement of Work	112
Format	Contract Amendment	113
Format	Completion Certificate	114-115
Format	Invitation for Tenders (IFT)	116-117

BANGLADESH PETROLEUM CORPORATION (BPC)



EXECUTING AGENCY:

EASTERN REFINERY LIMITED (ERL)
NORTH PATENGA, CHATTOGRAM-4204
BANGLADESH

Ref: Tender no. ER/DEV (M)-40(1)/2022

Date: Aug 07 , 2022

INVITATION TO TENDERERS

Gentleman,

On behalf of Bangladesh Petroleum Corporation, Eastern Refinery Limited (hereinafter referred to as ERL) intends to renovation of 01 (one) Crude Oil Storage Tank (T-6101C) at ERL Tank Farm Area, North Patenga, Chattogram.

Successful Tenderer will undertake renovation of 1 (one) **Crude Oil Storage Tank** having capacity of 32,000 cubic meter including cleaning, earth work, replacement of bottom, annular plate, roof, roof railing, wind girder, leg & leg casing, stairway, pipelines, tank mat, pad etc. and sandblasting, painting including attachments as required.

Having indicated an interest in performing the above work, you are, by this letter, invited to submit your tender in accordance with this Tender Document.

All bids are to be submitted in English Language.

Any contract resulting from this Invitation to Tender will be issued by ERL.

Yours truly,

(Mamshad Karim Anwar)
Assistant General Manager (Development)
Eastern Refinery Limited



EASTERN REFINERY LIMITED (ERL)
(A Subsidiary of Bangladesh Petroleum Corporation)
North Patenga, Chattogram
www.erl.gov.bd



INVITATION FOR NATIONAL TENDER

GOVERNMENT OF THE PEOPLES REPUBLIC OF BANGLADESH					
1	Ministry/Division		Ministry of Power, Energy and Mineral Resources/ Energy and Mineral Resources Division		
2	Agency		Bangladesh Petroleum Corporation		
3	Procuring Entity Name		Bangladesh Petroleum Corporation, Executing agency: Eastern Refinery Limited		
4	Procuring Entity District		Chattogram		
5	Invitation for		Renovation of Crude Oil Storage Tank No. T-6101C.		
6	Invitation Ref. No.		ER/DEV (M)-40(1)/2022		
7	Date		07/08/2022		
KEY INFORMATION:					
8	Procurement Method		National One Stage Two Envelope Tendering Method		
FUNDING INFORMATION:					
9	Budget and Source of Funds		Bangladesh Petroleum Corporation's (BPC) own fund		
PARTICULAR INFORMATION:					
10	Tender Package No.		ER/DEV (M)-40(1)/2022		
11	Tender Package Name		Renovation of Crude Oil Storage Tank No. T-6101C.		
12	Tender Publication Date		08/08/2022		
13	Tender Last Selling Date		05/09/2022		
14	Tender Closing Date and Time		06/09/2022, 15:00 Hrs		
15	Tender Opening Date and Time		Technical: 06/09/2022, 15:15 Hrs Commercial: Will be informed to the successful bidders.		
16	Name & Address of the office(s):				
	Selling Tender Document (Principal)		Manager (Material Accounts), Eastern Refinery Limited, North Patenga, Chattogram-4204, Bangladesh.		
	Selling Tender Document (Others)		AGM (DLO), ERL Liaison Office, YMCA Bhaban (2 nd Floor), 1/1, Pioneer Road, Kakrail, Dhaka-1000, Bangladesh.		
	Receiving Tender Document		Address: BPC Board Room, Bangladesh Petroleum Corporation (BPC), BSC Bhaban, Saltgola Road, Chattogram-4100, Bangladesh.		
	Opening Tender Document		Address: BPC Board Room, Bangladesh Petroleum Corporation (BPC), BSC Bhaban, Saltgola Road, Chattogram-4100, Bangladesh.		
INFORMATION FOR TENDERER:					
17	Brief Eligibility and Qualification of Tenderer		As per Tender Data Sheet (Section -2)		
18	Brief Description of Works		Renovation of Crude Oil Storage Tank No. T-6101C.		
19	Price of Tender Document (Tk.)		Tk. 1,000.00 (Taka one thousand) (each) (non-refundable)		
20	Lot No.	Identification of Lot	Location	Tender Security Amount (Tk.)	Completion Time in Days/ Weeks / Months
	1	ER/DEV (M)-40(1)/2022	Tank Farm Area of Eastern Refinery Limited, North Patenga, Chattogram	Tk. 2,00,000.00 (Taka Two lakh only)	270 (Two hundred and seventy) days from the date of getting hot work permit & electrical connection.
PROCURING ENTITY DETAILS:					
21	Name of Official Inviting Tender		Mamshad Karim Anwar		
22	Designation of Official Inviting Tender		Assistant General Manager (Development)		
23	Address of Official Inviting Tender		Eastern Refinery Limited, North Patenga, Chattogram-4204, Bangladesh.		
24	Contact details of Official Inviting Tender		Tele No.: 02333301261-7, Ext-460 Fax: 8802333301269. E-mail: agmdevelopment@erl.com.bd, md-office@erl.com.bd Website: www.erl.gov.bd, www.erl.com.bd		
25	a) The Procuring Entity reserves the right to reject all the Tenders or annul the Tender proceedings. b) If it is not possible to receive/open the tender on the scheduled date for any unavoidable circumstances, the same will be received/opened on the next working day at the same time and same venue.				



Section 1. Instructions to Tenderers

A. General

1. **Scope of Tender**
 - 1.1 The Procuring Entity, as indicated in the Tender Data Sheet (**TDS**) issues this Tender Document for the procurement of Works and physical services incidental thereto as specified in the **TDS** and as detailed in **Section 6: Bill of Quantities**. The name of the Tender and the number and identification of its constituent lot(s) are stated in the **TDS**.
 - 1.2 The successful Tenderer shall be required to execute the Works and physical services as specified in the General Conditions of Contract.
2. **Interpretation**
 - 2.1 Throughout this Tender Document:
 - (a) the term “in writing” means communication written by hand or machine duly signed and includes properly authenticated messages by facsimile or electronic mail;
 - (b) if the context so requires, singular means plural and vice versa;
 - (c) “day” means calendar days unless otherwise specified as working days;
 - (d) “Person” means and includes an individual, body of individuals, sole proprietorship, partnership, company, association or cooperative society that wishes to participate in Procurement proceedings;
 - (e) “Tenderer” means a Person who submits a Tender;
 - (f) “Tender Document” means the Document provided by a Procuring Entity to a Tenderer as a basis for preparation of the Tender; and
 - (g) “Tender” depending on the context, means a Tender submitted by a Tenderer for execution of Works and physical services to a Procuring Entity in response to an Invitation for Tender.
3. **Source of Funds**
 - 3.1 The Procuring Entity has been allocated public funds as indicated in the **TDS** and intends to apply a portion of the funds to eligible payments under the Contract for which this Tender Document is issued.
 - 3.2 For the purpose of this provision, “public funds” means any monetary resources appropriated to the Procuring Entity under Government budget, or loan, grants and credits placed at the disposal of the Procuring Entity through the Government by the development partners or foreign states or organisations.
 - 3.3 Payments by the development partner, if so indicated in the **TDS**, will be made only at the request of the Government and upon approval by the development partner or foreign state or Organisation in accordance with the applicable Loan/Credit/Grant Agreement, and will be subject in all respects to the terms and conditions of that Agreement.
4. **Corrupt, Fraudulent, Collusive, Coercive (or Obstructive in**
 - 4.1 The Government and the Development Partner, if applicable requires that the Procuring Entity as well as the Tenderers and Contracts (including, sub-contractors, agents, personnel, consultants, and service providers) shall observe the highest standard of ethics during implementation of procurement proceedings and the execution of Contracts under public funds.



case of
Development
Partner)
Practices

- 4.2 For the purposes of ITT Sub Clause 4.3, the terms set forth below as follows:
- (a) "Corrupt practice" means offering, giving or promising to give, receiving, or soliciting either directly or indirectly, to any officer or employee of the Procuring Entity or other public or private authority or individual, a gratuity in any form; employment or any other thing or service of value as an inducement with respect to an act or decision or method followed by the Procuring Entity in connection with a Procurement proceeding or Contract execution;
 - (b) "Fraudulent practice" means the misrepresentation or omission of facts in order to influence a decision to be taken in a Procurement proceeding or Contract execution;
 - (c) "Collusive practice" means a scheme or arrangement between two (2) or more Persons, with or without the knowledge of the Procuring Entity, that is designed to arbitrarily reduce the number of Tenders submitted or fix Tender prices at artificial, non-competitive levels, thereby denying the Procuring Entity the benefits of competitive price arising from genuine and open competition;
 - (d) "Coercive practice" means harming or threatening to harm, directly or indirectly, Persons or their property to influence a decision to be taken in the Procurement proceeding or the execution of a Contract, and this will include creating obstructions in the normal submission process used for Tenders.
 - (e) "Obstructive practice" (applicable in case of Development Partner) means deliberately destroying, falsifying, altering or concealing of evidence material to the investigation or making false statements to investigators in order to materially impede an investigation into allegations of a corrupt, fraudulent, coercive or collusive practice; and /or threatening, harassing or intimidating any party to prevent it from disclosing its knowledge of matters relevant to the investigation or from pursuing the investigation.
- 4.3 Should any corrupt, fraudulent, collusive, coercive (or obstructive in case of Development Partner) practice of any kind is determined by the Procuring Entity or the Development Partner, if applicable, this will be dealt in accordance with the provisions of the Public Procurement Act and Rules and Guidelines of the Development Partners as stated in the ITT Sub Clause 3.3. In case of obstructive practice, this will be dealt in accordance with Development Partners Guidelines.
- 4.4 If corrupt, fraudulent, collusive, coercive (or obstructive in case of Development Partner) practices of any kind is determined by the Procuring Entity against any Tenderer or Contracts (including sub-contractors, agents, personnel, consultants, and service providers) in competing for, or in executing, a contract under public fund:
- (a) Procuring Entity and/or the Development Partner shall exclude the concerned Tenderer from further participation in the concerned procurement proceedings;
 - (b) Procuring Entity and/or the Development Partner shall reject any recommendation for award that had been proposed for that concerned Tenderer;
 - (c) Procuring Entity and/or the Development Partner shall declare, at its discretion, the concerned Tenderer to be ineligible to participate in further



Procurement proceedings, either indefinitely or for a specific period of time.

- (d) Development Partner shall sanction the concerned Tenderer or individual, at any time, in accordance with prevailing Development Partner' sanctions procedures, including by publicly declaring such Tenderer or individual ineligible, either indefinitely or for a stated period of time: (i) to be awarded a Development Partner-financed contract; and (ii) to be a nominated sub-contractor, consultant, manufacturer or Contractor, or service provider of an otherwise eligible firm being awarded a Development Partner-financed contract; and
- (e) Development Partner shall cancel the portion of the loan allocated to a contract if it determines at any time that representatives of the Procuring Entity or of a beneficiary of the loan engaged in corrupt, fraudulent, collusive, coercive or obstructive practices during the procurement or the execution of that Development Partner financed contract, without the Procuring Entity having taken timely and appropriate action satisfactory to the Development Partner to remedy the situation.

4.5 Tenderer shall be aware of the provisions on corruption, fraudulence, collusion, coercion (and obstruction, in case of Development Partner) of the Public Procurement Act, 2006, the Public Procurement Rules, 2008 and others as stated in GCC Clause 38.

4.6 In further pursuance of this policy, Tenderers, Contractors and their sub-contractors, agents, personnel, consultants, service providers shall permit the Government and the Development Partner to inspect any accounts and records and other documents relating to the Tender submission and contract performance, and to have them audited by auditors appointed by the Government and/or the Development Partner during the procurement or the execution of that Development Partner financed contract.

5. Eligible Tenderers

- 5.1 This Invitation for Tenders is open to all potential Tenderers from all countries, except for any specified in the TDS.
- 5.2 Tenderers shall have the legal capacity to enter into the Contract under the Applicable law.
- 5.3 Tenderers shall be enrolled in the relevant professional or trade organisations registered in Bangladesh.
- 5.4 Tenderers may be a physical or juridical individual or body of individuals, or company, association or any combination of them in the form of a Joint Venture (JV) invited to take part in public procurement or seeking to be so invited or submitting a Tender in response to an Invitation for Tenders.
- 5.5 Tenderers shall have fulfilled its obligations to pay taxes and social security contributions under the provisions of laws and regulations of the country of its origin.
- 5.6 Tenderers should not be associated, or have been associated in the past, directly or indirectly, with a consultant or any of its affiliates which have been engaged by the Procuring Entity to provide consulting services for the preparation of the design, specifications, and other documents to be used for the procurement of the works to be performed under this Invitation for Tenders.
- 5.7 Tenderers in its own name or its other names or also in the case of its Persons in different names shall not be under a declaration of ineligibility for corrupt, fraudulent, collusive or coercive practices as stated under ITT Sub



Clause 4.4 (or obstructive practice, in case of Development Partner) in relation to the Development Partner's Guidelines in projects financed by Development Partner.

- 5.8 Tenderers are not restrained or barred from participating in Public Procurement on grounds of poor performance in the past under any Contract.
- 5.9 Tenderers shall not be insolvent, be in receivership, be bankrupt, be in the process of bankruptcy, be not temporarily barred from undertaking business and it shall not be the subject of legal proceedings for any of the foregoing.
- 5.10 Government-owned enterprise in Bangladesh may also participate in the Tender if it is legally and financially autonomous, it operates under commercial law, and it is not a dependent agency of the Procuring Entity.
- 5.11 Tenderers shall provide such evidence of their continued eligibility satisfactory to the Procuring Entity, as the Procuring Entity will reasonably request.
- 5.12 These above requirements for eligibility will extend, as applicable, to each JV partner and Subcontractor proposed by the Tenderers.
- 5.13 Tenderers shall have the up-to-date valid license(s), issued by the corresponding competent authority, as specified in the **TDS**.

B. Tender Document

6. **Eligible Materials, Equipment and Associated Services**
 - 6.1 All materials, equipment and associated services to be supplied under the Contract are from eligible sources, unless their origin is from a country specified in the **TDS**.
 - 6.2 For the purposes of this Clause, "origin" means the place where the Materials and Equipments are mined, grown, cultivated, produced or manufactured or processed, or through manufacturing, processing, or assembling, another commercially recognized new product results that differs substantially in its basic characteristics from its components or the place from which the associated services are supplied.
 - 6.3 The origin of materials and equipment and associated services is distinct from the nationality of the Tenderer.
7. **Site Visit**
 - 7.1 Tenderers are advised to visit and examine the Site of Works and its surroundings and obtain for itself on its own responsibility all information that may be necessary for preparing the Tender and entering into a contract for construction of the Works. The costs of visiting the Site shall be at Tenderer's own expense.
8. **Tender Document: General**
 - 8.1 The Sections comprising the Tender Document are listed below, and should be read in conjunction with any Addendum issued under ITT Clause 11.
 - Section 1 Instructions to Tenderers (**ITT**)
 - Section 2 Tender Data Sheet (**TDS**)
 - Section 3 General Conditions of Contract (**GCC**)
 - Section 4 Particular Conditions of Contract (**PCC**)
 - Section 5 Tender and Contract Forms
 - Section 6 Bill of Quantities (**BOQ**)
 - Section 7 General Specifications



- Section 8 Particular Specifications
 - Section 9 Drawings
- 8.2 The Procuring Entity is not responsible for the completeness of the Tender Document and their addenda, if these were not purchased directly from the Procuring Entity, or through its agent as specified in the **TDS**.
- 8.3 Tenderers are expected to examine all instructions, forms, terms, and specifications in the Tender Document as well as in addendum to Tender, if any.
- 9. Clarification of Tender Document**
- 9.1 A prospective Tenderer requiring any clarification of the Tender Document shall contact the Procuring Entity in writing at the Procuring Entity's address and within time as specified in the **TDS**.
- 9.2 The Procuring Entity is not obliged to answer any clarification request received after that date as stated under ITT Sub Clause 9.1.
- 9.3 The Procuring Entity shall respond in writing within five (5) working days of receipt of any such request for clarification received under ITT Sub Clause 9.1.
- 9.4 The Procuring Entity shall forward copies of its response to all those who have purchased the Tender Document, including a description of the enquiry but without identifying its source.
- 9.5 Should the Procuring Entity deem it necessary to revise the Tender Document as a result of a clarification, it will do so following the procedure under ITT Clause 11.
- 10. Pre-Tender Meeting**
- 10.1 To clarify issues and to answer questions on any matter arising in the Tender Document, the Procuring Entity may, if stated in the **TDS**, hold a pre-Tender Meeting at the place, date and time as specified in the **TDS**. All potential Tenderers are encouraged and invited to attend the meeting, if it is held.
- 10.2 Tenderers are requested to submit any questions in writing so as to reach the Procuring Entity not later than one day prior to the date of the meeting.
- 10.3 Minutes of the pre-Tender meeting, including the text of the questions raised and the responses given, together with any responses prepared after the meeting, will be transmitted within five (5) working days after holding the meeting to all those who purchased the Tender document and to even those who did not attend the meeting. Any revision to the Tender Document listed in ITT Sub Clause 8.1 that may become necessary as a result of the pre-Tender meeting will be made by the Procuring Entity exclusively through the issue of an Addendum pursuant to ITT Sub Clause 11 and not through the minutes of the pre-Tender meeting.
- 10.4 Non-attendance at the Pre-Tender meeting will not be a cause for disqualification of a Tenderer.
- 11. Addendum to Tender Document**
- 11.1 At any time prior to the deadline for submission of Tenders, the Procuring Entity, on its own initiative or in response to an inquiry in writing from a Tenderer, having purchased the Tender Document, or as a result of a pre-Tender meeting may revise the Tender Document by issuing an Addendum.
- 11.2 The Addendum issued under ITT Sub Clause 11.1 shall become an integral part of the Tender Document and shall have a date and an issue number and must be circulated by fax, mail or e-mail, to Tenderers who have purchased the Tender



Documents, within five (5) working days of issuance of such Addendum, to enable Tenderers to take appropriate action.

- 11.3 The Procuring Entity shall also ensure posting of the relevant addenda with the reference number and date on their websites including notice boards, where the Procuring Entity had originally posted the IFTs.
- 11.4 To give a prospective Tenderer reasonable time in which to take an addendum into account in preparing its Tender, the Procuring Entity may, at its discretion, extend the deadline for the submission of Tenders, pursuant to ITT Sub Clause 42.2.
- 11.5 If an addendum is issued when time remaining is less than **one-third** of the time allowed for the preparation of Tenders, the Procuring Entity at its discretion shall extend the deadline by an appropriate number of days for the submission of Tenders, depending upon the nature of the Procurement requirement and the addendum. In any case, the minimum time for such extension shall not be less than three (3) working days.

C. Qualification Criteria

12. **General Criteria**
 - 12.1 Tenderers shall possess the necessary professional and technical qualifications and competence, financial resources, equipment and other physical facilities, managerial capability, specific experience, reputation, and the personnel, to perform the contract, which entails setting pass/fail criteria, which if not met by the Tenderers, will result in consideration of its Tender as non-responsive as specified in the **TDS**.
 - 12.2 In addition to meeting the eligibility criteria, as stated in ITT Clause 5, Tenderers must satisfy the other criteria stated in ITT Clauses 13 to 18 inclusive.
 - 12.3 To qualify for multiple number of contracts/lots in a package made up of this and other individual contracts/lots for which Tenders are invited in the Invitation for Tenders, the Tenderers shall demonstrate having resources sufficient to meet the aggregate of the qualifying criteria for the individual contracts. The requirement of general experience as stated under ITT Sub Clause 14.1(a) and specific experience, unless otherwise of different nature, as stated under ITT Sub Clause 14.1(b) shall not be separately applicable for each individual lot.
13. **Litigation History**
 - 13.1 Litigation history shall comply with the requirement as stated under ITT Sub Clause 15.1(c).
14. **Experience Criteria**
 - 14.1 Tenderers shall have the following minimum level of construction experience to qualify for the performance of the Works under the Contract:
 - (a) a minimum number of years of general experience in the construction of works as Prime Contractor or Subcontractor or Management Contractor as specified in the **TDS**; and
 - (b) specific experience as a Prime Contractor or Subcontractor or Management Contractor in construction works of a nature, complexity and methods/construction technology similar to the proposed Works, in at least a number of contract(s) and, each with a minimum value over the period, as specified in the **TDS**.



15. **Financial Criteria**
- 15.1 Tenderers shall have the following minimum level of financial capacity to qualify for the performance of the Works under the Contract.
- the average annual construction turnover as specified in the **TDS** during the period specified in the **TDS**;
 - availability of minimum liquid assets i.e., working capital or credit facilities from any scheduled Bank of Bangladesh, net of other contractual commitments, of the amount as specified in the **TDS**;
 - satisfactory resolution of all claims under litigation cases and shall not have serious negative impact on the financial capacity of the Tenderers. All pending litigation shall be treated as resolved against the Tenderers; and
 - the Minimum Tender Capacity as specified in the **TDS**.
16. **Personnel Capacity**
- 16.1 Tenderers shall have the following minimum level of personnel capacity to qualify for the performance of the Works under the Contract consisting of a Construction Project Manager, Engineers, and other key staff with qualifications and experience as specified in the **TDS**.
17. **Equipment Capacity**
- 17.1 Tenderers shall own suitable equipment and other physical facilities or have proven access through contractual arrangement to hire or lease such equipment or facilities for the desired period, where necessary or have assured access through lease, hire, or other such method, of the essential equipment, in full working order, as specified in the **TDS**.
18. **Joint Venture (JV)**
- 18.1 Tenderers may participate in the procurement proceedings forming a Joint Venture (JV) by an agreement, executed case by case on a non judicial stamp of value as specified in the **TDS** or alternately with the intent to enter into such an agreement supported by a Letter of Intent along with the proposed agreement duly signed by all legally authorised partners of the intended JV and authenticated by a Notary Public, with the declaration that the partners will execute the JV agreement in the event the Tenderer is successful.
- 18.2 The figures for each of the partners of a JV shall be added together to determine the Tenderer's compliance with the minimum qualifying criteria; however, for a JV under ITT Sub Clause 18.1, with number of partners as specified in the **TDS** to qualify, Leading partner and other partners must meet the criteria as specified in the **TDS**. Failure to comply with these requirements will result in non-responsiveness of the JV Tender.
- 18.3 Each partner of the JV shall be jointly and severally liable for the execution of the Contract, all liabilities and ethical and legal obligations in accordance with the Contract terms.
- 18.4 JV shall nominate the **Leading Partner** as **REPRESENTATIVE** being entrusted with the Contract administration and management at Site who shall have the authority to conduct all business for and on behalf of any and all the partners of the JV during the Tendering process and, in the event the JV is awarded the Contract, during contract execution including the receipt of payments for and on behalf of the JV.
19. **Subcontractor(s)**
- 19.1 Tenderers may intend to subcontract an activity or part of the Works, in which case such elements and the proposed Subcontractor shall be clearly identified.
- 19.2 The Procuring Entity may require Tenderers to provide more information about their subcontracting arrangements. If any Subcontractor is found ineligible or unsuitable to carry out the subcontracted tasks, the Procuring Entity may request the Tenderers to propose an acceptable substitute.
- 19.3 A Subcontractor may participate in more than one Tender, but only in that



capacity.

- 19.4 The Procuring Entity may also select in advance Nominated Subcontractor(s) to execute certain specific components of the Works and if so, those will be specified in the **TDS**.
- 19.5 The successful Tenderer shall under no circumstances assign the Works or any part of it to a Subcontractor.

D. Tender Preparation

- 20. Only one Tender**
- 20.1 Tenderers shall submit only one (1) Tender for each lot, either individually or as a JV. Tenderer who submits or participates in more than one (1) Tender in one (1) lot of a package or in one (1) package with one (1) lot will cause all the Tenders of that particular Tenderer to be rejected.
- 21. Cost of Tendering**
- 21.1 Tenderers shall bear all costs associated with the preparation and submission of its Tender, and the Procuring Entity shall not be responsible or liable for those costs, regardless of the conduct or outcome of the Tendering process.
- 22. Issuance and Sale of Tender Document**
- 22.1 The Procuring Entity shall make Tender Documents available immediately to the potential Tenderers, requesting and willing to purchase at the corresponding price by the date the advertisement has been published in the newspaper.
- 22.2 There shall not be any pre-conditions whatsoever, for sale of Tender Documents and the sale of such Document shall be permitted up to the day prior to the day of deadline for the submission of Tender.
- 23. Language of Tender**
- 23.1 Tenders shall be written in the English language. Correspondences and documents relating to the Tender may be written in English or Bangla. Supporting documents and printed literature furnished by the Tenderers that are part of the Tender may be in another language, provided they are accompanied by an accurate translation of the relevant passages in the English or Bangla language, in which case, for purposes of interpretation of the Tender, such translation shall govern.
- 23.2 Tenderers shall bear all costs of translation to the governing language and all risks of the accuracy of such translation.
- 24. Contents of Tender**
- 24.1 The Tender prepared by the Tenderers shall comprise Two Envelope submitted simultaneously, one called the **Technical Offer (Envelope -01)** containing the documents listed in ITT 24.2 and other called the **Financial Offer** containing the documents listed in 24.3, both envelopes enclosed together in an outer Single envelope.



- 24.2 The **Technical Offer (Envelope-01)** prepared by the Tenderers will comprise the following:
- a) the Technical Offer Submission Letter (**Form PW3A-1a**), as stated under ITT Sub Clause 25.1;
 - b) the Tenderer Information as stated under ITT Clauses 5, 29 and 32 (**Form PW3A-2**);
 - c) the Tender Security as stated under ITT Clauses 35, 36 and 37;
 - d) the alternatives, if permissible, as stated under ITT Clause 26;
 - e) the written confirmation authorizing the signatory of the Tender to commit the Tenderer, as stated under ITT Sub Clause 40.3;
 - f) the Valid Trade license;
 - g) documentary evidence of Tax Identification Number (TIN) and Value Added Tax (VAT) as a proof of taxation obligations as stated under ITT Sub Clause 5.5;
 - h) the Technical Proposal describing work plan & method, personnel, equipment and schedules as stated under ITT Clause 31;
 - i) documentary evidence as stated under ITT Clause 29 and 32 establishing the Tenderer's eligibility and the minimum qualifications of the Tenderers required to be met for due performance of the Works and physical services under the Contract;
 - j) document establishing legal and financial autonomy and compliance with commercial law, as stated under ITT Sub Clause 5.10 in case of government owned entity;
 - k) any other document as specified in the **TDS**.
- 24.3 The **Financial Offer (Financial Envelope -02)** prepared by the Tenderers will comprise the following:
- a) the Financial Offer Submission Letter (**Form PW3A-1b**), as stated under ITT Sub Clause 25.2;
 - b) the **priced BOQ** for each lot in accordance with ITT Clauses 25, 27 and 28;
 - c) the written confirmation authorizing the signatory of the Tender to commit the Tenderer, as stated under ITT Sub Clause 40.4;
 - d) any other document as specified in the **TDS**.
25. **Tender Submission Letter and Bill of Quantities**
- 25.1 Tenderers shall submit the Technical Offer Submission Letter (**Form PW3A-1a**), which shall be completed without any alterations to its format, filling in all blank spaces with the information requested, failing which the Tender may be rejected as being incomplete.
 - 25.2 Tenderers shall submit the Financial Offer submission letter (**Form PW3A-1b**) along with priced BOQ using the form(s) furnished in **Section 6: Bill of Quantities**.
 - 25.3 If in preparing its Tender, the Tenderer has made errors in the unit rate or the total price, and wishes to correct such errors prior to submission of its Tender, it may do so, but shall ensure that each correction is initialled by the authorised person of the Tenderer.
26. **Alternatives**
- 26.1 Unless otherwise specified in the **TDS**, alternative technical solutions shall not be considered.



- 26.2 When specified in ITT clause 26.1, Tenderers are permitted to submit alternative technical solutions for specified parts of the Works, and such parts will be identified in the **TDS**.
- 26.3 Only the technical alternatives, if any, of the lowest evaluated Tenderer conforming to the basic technical requirements will be considered by the Procuring Entity.
27. **Tender Prices, Discounts and Price Adjustment**
- 27.1 The prices and discounts shall be quoted by the Tenderers in the Financial Offer Submission Letter (**Form PW3A-1b**).
- 27.2 Tenderers shall fill in unit rates for all items of the Works both in figures and in words as described in the BOQ, excluding any discount offered.
- 27.3 The items quantified in the BOQ for which no unit rates have been quoted by the Tenderer will not be paid for, by the Procuring Entity when executed and shall be deemed covered by the amounts of other rates in the BOQ and, it shall not be a reason to change the Tender price.
- 27.4 The price to be quoted in the Financial Offer Submission Letter (**Form PW3A-1b**), as stated under ITT Sub Clause 25.2, shall be the total price of the Tender, **excluding any discounts offered**.
- 27.5 Tenderers shall quote any unconditional discounts in the Financial Offer Submission Letter as stated under ITT Sub Clause 25.2.
- 27.6 Tenderers wishing to offer any unconditional discount to any package or lot as applicable shall mention discount in percentage (%) in the Financial Offer Submission Letter (**Form PW3A-1b**). Discount shall be equally applicable on all the items of BOQ and shall be applied after arithmetic correction of the tender.
- 27.7 All applicable taxes, custom duties, VAT and other levies payable by the Contractor under the Contract, or for any other causes, as of the date twenty-eight (28) days prior to the deadline for submission of Tenders, shall be included in the unit rates and the total Tender price submitted by the Tenderers.
- 27.8 Unless otherwise specified in the **TDS** and provided in the Contract, the price of a Contract shall be fixed in which case the unit rates may not be modified in response to changes in economic or commercial conditions.
- 27.9 If so stated under ITT Sub Clause 27.9, Tenders are being invited with a provision for price adjustments. The unit rates quoted by the Tenderers are subject to adjustment during the performance of the Contract in accordance with the provisions of General Condition of Contract (**GCC**) Clause 69 and, in such case the Procuring Entity shall provide the indexes and weightings or coefficients in **Appendix to the Tender (Table 1.1 and Table 1.2)** for the price adjustment formulae as specified in the Particular Conditions of Contract (**PCC**).
28. **Tender Currency**
- 28.1 Tenderers shall quote all prices in the Financial Offer Submission Letter and in the BOQ in Bangladesh Taka (BDT) currency.
29. **Documents Establishing Eligibility of the Tenderer**
- 29.1 Tenderers, if applying as a sole Tenderer, shall submit documentary evidence to establish its eligibility as stated under ITT Clause 5 and, in particular, it shall:
- complete the eligibility declarations in the Technical Offer Submission Letter (**Form PW3A-1a**);
 - complete the Tenderer Information (**Form PW3A-2**);
 - complete Subcontractor Information (**Form PW3A-4**), if it intends to engage any Subcontractor(s).



- 29.2 Tenderers, if applying as a partner of an existing or intended JV shall submit documentary evidence to establish its eligibility as stated under ITT Clause 5 and, in particular, in addition to as stated under ITT Sub Clause 29.1, it shall:
- (a) provide for each JV partner, completed JV Partner Information (**Form PW3A-3**);
 - (b) provide the JV agreement or Letter of Intent along with the proposed agreement of the intended JV as stated under ITT Sub Clause 18.1.
30. Documents Establishing the Eligibility and Conformity of Materials, Equipment and Services
- 30.1 Tenderers shall submit documentary evidence to establish the origin of all Materials, Equipment and services to be supplied under the Contract as stated under ITT Clause 6.
- 30.2 To establish the conformity of the Materials, Equipment and services to be supplied under the Contract, the Tenderers shall furnish, as part of its Tender, the documentary evidence (which may be in the form of literature, specifications and brochures, drawings or data) that these conform to the technical specifications and standards specified in **Section 7: General Specifications** and **Section 8: Particular Specifications**.
31. Documents Establishing Technical Proposal
- 31.1 Tenderers shall furnish a Technical Proposal including a statement of work methods, equipment, personnel, schedule and any other information as stipulated in **TDS**, in sufficient detail to demonstrate the adequacy of the Tenderer's proposal to meet the work requirements and the completion time.
32. Documents Establishing the Tenderer's Qualification
- 32.1 Tenderers shall complete and submit the Tenderer Information (**Form PW3A-2/PW3A-3**) and shall include documentary evidence, as applicable to satisfy the following:
- (a) general experience, of the entity(s) participating in the Tender, in construction works as stated under ITT Sub Clause 14.1(a), substantiated by the year of registration/constitution/licensing in its country of origin;
 - (b) specific experience, of the entity(s) participating in the Tender, in construction works under public sector of similar nature and size as stated under ITT Sub Clause 14.1(b), substantiated by Completion Certificate (s) issued by the relevant Procuring Entity(s);
 - (c) average annual **construction** turnover i.e., total certified payments received for contracts in progress or completed under public sector for a period as stated under ITT Sub Clause 15.1(a), substantiated by Statement(s) of Receipts, from any scheduled Bank of Bangladesh, issued not earlier than twenty-eight (28) days prior to the day of the original deadline for submission of Tenders;
 - (d) adequacy of minimum liquid assets i.e., working capital substantiated by Audit Reports mentioned in (i) below or credit line(s) substantiated by any scheduled Bank of Bangladesh in the format as specified (**Form PW3A-7**), without alteration, issued not earlier than twenty-eight (28) days prior to the day of the original deadline for submission of Tenders for this Contract as stated under ITT Sub Clause 15.1(b);
 - (e) information regarding claims under litigation, current or during the last years as specified in the **TDS**, in which the Tenderer is involved, the parties concerned, and value of claim as stated under ITT Sub Clause 15.1(c), substantiated by statement(s) of the entity(s) participating in the Tender in its letter-head pad;
 - (f) technical and administrative personnel along with their qualification and experience proposed for the Contract as stated under ITT Clause 16;
 - (g) major items of construction equipment proposed to carry out the



Contract as stated under ITT Clause 17, substantiated by statement(s) of the entity(s) participating in the Tender in its letter-head pad declaring source of its availability;

- (h) authority(s), to seek references from the Tenderer's Bankers or any other sources, of the entity(s) participating in the Tender in its letter-head pad;
 - (i) reports on the financial standing of the Tenderer, such as profit and loss statements and audited balance sheet for the past years as specified in the **TDS**, of the entity(s) participating in the Tender, substantiated by Audit Reports.
33. **Validity Period of Tender** 33.1 Tenders shall remain valid for the period as specified in the **TDS** after the date of Tender submission deadline. A Tender valid for a period shorter than that specified will be considered, non-responsive.
34. **Extension of Tender Validity and Tender Security** 34.1 In exceptional circumstances, prior to the expiration of the Tender Validity period, the Procuring Entity may solicit all the Tenderers' consent to an extension of the period of validity of their Tenders; provided that those Tenderers have passed the preliminary examination as stated under ITT Sub Clause 51.2.
- 34.2 The request for extension of Tender Validity period shall state the new date of the validity of the Tender.
- 34.3 The request and the responses shall be made in writing. Validity of the Tender Security provided under ITT Clause 35 shall also be suitably extended for twenty-eight (28) days beyond the new date for the expiry of the Tender Validity. If a Tenderer does not respond or refuses the request it shall not forfeit its Tender Security, but its Tender shall no longer be considered in the evaluation proceedings. A Tenderer agreeing to the request will not be required or permitted to modify its Tender.
35. **Tender Security** 35.1 Tenderers shall furnish tender security as part of its **Technical offer**, in favour of the Procuring Entity or as otherwise directed on account of the Tenderer, a Tender Security in original form (not copy) and in the amount, as specified in the **TDS**.
- 35.2 If the Tender is a Joint Venture, the Tenderer shall furnish as part of its Tender, in favour of the Procuring Entity or as otherwise directed on account of the title of the existing or intended JV or any of the partners of that JV or in the names of all future partners as named in the Letter of Intent of the JV, a Tender Security in original form and in the amount as stated under ITT Sub Clause 35.1.
- 35.3 In case of substitution of the Tender as stated under ITT Clause 46 a new Tender Security shall be required in the substituted Tender.
36. **Form of Tender Security** 36.1 The Tender Security shall:
- (a) at the Tenderer's option, be either;
 - i. in the form of a Bank Draft or Pay Order, or
 - ii. in the form of an irrevocable unconditional Bank Guarantee issued by any scheduled Bank of Bangladesh, in the format (**Form PW3A-6**), without any alteration, furnished in **Section 5: Tender and Contract Forms**;
 - (b) be payable promptly upon written demand by the Procuring Entity in the case of the conditions as stated under ITT Sub Clause 39.1 being invoked; and
 - (c) remain valid for at least twenty-eight (28) days beyond the expiry date of the Tender Validity in order to make a claim in due course against a Tenderer



in the circumstances as stated under ITT Sub Clause 39.1.

37. Authenticity of Tender Security
- 37.1 The authenticity of the Tender Security submitted by a Tenderer may be examined and verified by the Procuring Entity at its discretion in writing from the Bank issuing the security.
- 37.2 If a Tender Security is found to be not authentic, the Procuring Entity may proceed to take measures against that Tenderer as stated under ITT Sub Clause 4.4.
- 37.3 A Tender not accompanied by a valid Tender Security will be considered non-responsive.
38. Return of Tender Security
- 38.1 No Tender Security shall be returned to the Tenderers before contract signing.
- 38.2 Unsuccessful Tenderer's Tender Security will be discharged or returned as soon as possible but within twenty-eight (28) days after the expiry of the Tender Validity period as stated under ITT Sub Clauses 33.1.
- 38.3 The Tender security of non-responsive Tenderers shall be returned immediately after the evaluation report approved by the Approving Authority.
- 38.4 The Tender Security of the successful Tenderer will be discharged upon the Tenderer's furnishing of the performance security and signing of the Contract Agreement.
39. Forfeiture of Tender Security
- 39.1 The Tender Security may be forfeited, if a Tenderer:
- (a) withdraws its Tender after opening of Tenders but within the validity of the Tender as stated under ITT Clause 33 and 34; or
 - (b) refuses to accept a Notification of Award as stated under ITT Sub Clause 67.3; or
 - (c) fails to furnish Performance Security as stated under ITT Sub Clause 68.1 and 68.2; or
 - (d) refuses to sign the Contract as stated under ITT Sub Clause 72.2; or
 - (e) does not accept the correction of the Tender price following the correction of the arithmetic errors as stated under ITT Clause 58.
40. Format and Signing of Tender
- 40.1 Tenderers shall prepare one (1) original of the documents comprising the **Technical Offer** as described in ITT Clause 24.2 and clearly mark it "**ORIGINAL OF TECHNICAL OFFER**". In addition, the Tenderers shall prepare the number of copies of the Technical Offer, as specified in the TDS and clearly mark each of them "**COPY OF THE TECHNICAL OFFER**." In the event of any discrepancy between the original and the copies, the **ORIGINAL** shall prevail.
- 40.2 Tenderers shall prepare one (1) original of the documents comprising the Financial Offer as described in ITT Clause 24.3 and clearly mark it "**ORIGINAL OF FINANCIAL OFFER**". In addition, the Tenderers shall prepare the number of copies of the Financial Offer, as specified in the TDS and clearly mark each of them "**COPY OF THE FINANCIAL OFFER**". In the event of any discrepancy between the original and the copies, the **ORIGINAL** shall prevail.
- 40.3 Alternatives, if permitted as stated under ITT Clause 26, shall be clearly marked "Alternative".



- 40.4 The original and each copy of the Offer shall be typed or written in indelible ink and shall be signed by the Person duly authorized to sign on behalf of the Tenderer. This Tender specific authorization shall be attached to the Technical Offer Submission Letter (**Form PW3A-1a**) and Financial Offer Submission Letter (**Form PW3A-1b**). The name and position held by each Person(s) signing the authorization must be typed or printed below the signature. All pages of the original and of each copy of the Tender, except for un-amended printed literature, shall be numbered sequentially and signed by the person signing the Tender.
- 40.5 Any interlineations, erasures, or overwriting will be valid only if they are signed or initialled by the Person(s) signing the Tender.

E. Tender Submission

41. Sealing, & Marking of Tender

- 41.1 Tenderers shall enclose the original of **Technical Offer** in one (1) envelope and all the copies of the **Technical Offer**, including the alternatives, if permitted under ITT Clause 26, in another envelope, duly marking the envelopes as **“ORIGINAL OF TECHNICAL OFFER”**, **“ALTERNATIVES” (if permitted)**, **“COPY OF TECHNICAL OFFER”**, **“ALTERNATIVES” (if permitted)**. These sealed envelopes for the original and copies of the technical Tender shall then be enclosed and sealed in one single envelope and clearly mark it **“Envelope-01: TECHNICAL OFFER”**.
- 41.2 The inner and outer envelopes of Technical Offer shall:
- (a) be addressed to the Procuring Entity at the address as stated under ITT Sub Clause 42.1;
 - (b) bear the name of the Tender and the Tender Number as stated under ITT Sub Clause 1.1;
 - (c) bear the name and address of the Tenderer;
 - (d) bear a statement **“DO NOT OPEN BEFORE -----”** the time and date for Tender opening as stated under ITT Sub Clause 48.1;
 - (e) bear any additional identification marks as specified in the **TDS**.
- 41.3 Tenderers shall enclose the original of **Financial Offer** in one (1) envelope and all the copies of the **Financial Offer** in another envelope, duly marking the envelopes as **“ORIGINAL OF FINANCIAL OFFER”** & **“COPY OF FINANCIAL OFFER”**. These sealed envelopes for the original and copies of the Financial Tender shall then be enclosed and sealed in one single envelope and clearly mark it **“ENVELOPE-02: FINANCIAL OFFER”**.
- 41.4 The inner and outer envelopes of Financial Offer shall:
- (a) be addressed to the Procuring Entity at the address as stated under ITT Sub Clause 42.1;
 - (b) bear the name of the Tender and the Tender Number as stated under ITT Sub Clause 1.1;
 - (c) bear the name and address of the Tenderer;
 - (d) bear a statement **“DO NOT OPEN BEFORE THE TECHNICAL OFFER EVALUATION AND APPROVAL”**.
 - (e) bear any additional identification marks as specified in the **TDS**.



- 41.5 **The Envelope-01** as stated in ITT Clause 41.1 and **Envelope-02** as in ITT Clause 41.3 shall then be enclosed and sealed in one single outer envelope which shall contain the information as stated under ITT Clause 41.2 (a) to (e) & ITT Clause 41.4 (a) to (e).
- 41.6 Tenderers are solely and entirely responsible for pre-disclosure of Tender information if the envelope(s) are not properly sealed and marked.
- 41.7 Tenders shall be delivered by hand or by mail, including courier services at the address(s) as stated under ITT Sub Clause 42.1.
- 41.8 The Procuring Entity will, on request, provide the Tenderer with acknowledgement of receipt showing the date and time when it's Tender was received.
42. **Deadline for Submission of Tender**
- 42.1 Tenders shall be delivered to the Procuring Entity at the address specified in the **TDS** and not later than the date and time specified in the **TDS**.
- 42.2 The Procuring Entity may, at its discretion, extend the deadline for submission of Tender as stated under ITT Sub Clause 42.1, in which case all rights and obligations of the Procuring Entity and Tenderers previously subject to the deadline will thereafter be subject to the new deadline as extended.
- 42.3 If submission of Tenders is allowed in more than one location, the date and time, for submission of Tenders for both the primary and the secondary place(s), shall be the **“same and not different”** as specified in the **TDS**.
- 42.4 The Procuring Entity shall ensure that the Tenders received at the secondary place(s) are hand-delivered at the primary place as stated under ITT Sub Clause 42.1, within **THREE (3) HOURS** after the deadline for submission of Tenders at the secondary place (s), in case of **MULTIPLE DROPPING** as stated under ITT Sub Clause 42.3, as specified in the **TDS**.
43. **Late Tender**
- 43.1 Any Tender received by the Procuring Entity after the deadline for submission of Tenders as stated under ITT Sub Clause 42.1 shall be declared **LATE TENDER** and returned unopened to the Tenderer.
44. **Modification, Substitution or Withdrawal of Tender**
- 44.1 Tenderers may modify, substitute or withdraw its Tender after it has been submitted by sending a written notice duly signed by the authorized signatory and properly sealed, and shall include a copy of the authorization; provided that such written notice including the **affidavit** is received by the Procuring Entity prior to the deadline for submission of Tenders as stated under ITT Clause 42.
45. **Tender Modification**
- 45.1 Tenderers shall not be allowed to retrieve its original Tender, but shall be allowed to submit corresponding modification either to its original **Technical Offer** or **Financial Offer** or both, marked as **“MODIFICATION FOR TECHNICAL OFFER (MTO)”** or **“MODIFICATION FOR FINANCIAL OFFER (MFO)”** with two separate envelopes. The envelope/envelopes marked as MTO and/or MFO then be enclosed and sealed in one single outer envelope with a written notice duly as stated under ITT Sub Clause 44.1. The outer envelope shall contain the information as stated under ITT Sub Clause 41.2 (a) to (e) and clearly marked as **“MODIFICATION (M)”**.
46. **Tender Substitution**
- 46.1 Tenderers shall not be allowed to retrieve its original Tender, but shall be allowed to submit another **Technical Offer** or **Financial Offer** or both, marked as **“SUBSTITUTION FOR TECHNICAL OFFER (STO)”** or **“SUBSTITUTION FOR FINANCIAL OFFER (SFO)”** with two separate envelopes. The envelope/envelopes marked as STO and/or SFO then be enclosed and sealed in one single outer envelope with a written



notice duly as stated under ITT Sub Clause 44.1. The outer envelope shall contain the information as stated under ITT Sub Clause 41.2 (a) to (e) and clearly marked as “**SUBSTITUTION (S)**”.

47. **Tender Withdrawal** 47.1 Tenderers shall be allowed to withdraw its Tender by a Letter of Withdrawal marked as “**WITHDRAWAL (W)**”.

F. Tender Opening and Evaluation

48. **Tender Opening** 48.1 Only the **Technical Offer (Envelope-1)** shall be opened immediately after the deadline for submission of Tenders at the primary place as specified in the TDS but not later than **ONE HOUR**, after expiry of the submission deadline at the same primary place unless otherwise stated under ITT Sub Clause 42.2. Tender opening shall not be delayed on the plea of absences of Tenderers or his or her representatives. Financial offer (**Envelope-2**) shall not open with Technical offer (**Envelope-1**) and shall be kept unopened at the Custody of the Head of the Procuring Entity or his Authorised Officer (AO).
- 48.2 Persons not associated with the Tender may not be allowed to attend the public opening of Technical Offers.
- 48.3 Tenderers’ representatives shall be duly authorised by the Tenderer. Tenderers or their authorised representatives will be allowed to attend and witness the opening of Technical Offers, and will sign a register evidencing their attendance. Technical Offers Opening shall not be delayed on the plea of absence of Tenderers or his or her representatives.
- 48.4 The authenticity of withdrawal or substitution of, or modifications to original Tender, if any made by a Tenderer in specified manner, shall be examined and verified by the Tender Opening Committee (TOC) based on documents submitted as stated under ITT Sub Clause 44.1. Any envelope related to financial modification, substitute shall be recorded but not open with technical offer.
- 48.5 Verify (**M**), (**S**), (**W**), (**A**), (**O**) by following step by step:
- (a) **Step 1:** envelopes marked “**Withdrawal (W)**” shall be opened and “Withdrawal” notice read aloud & recorded in the opening sheet. After verify the withdrawal letter is genuine, corresponding tender shall not be opened, but returned unopened to the Tenderer by Procuring Entity (PE) at a late time. No Tender withdrawal shall be permitted unless the corresponding withdrawal notice shall be as stated in 44.1 & 47.1 and in such case the Tender shall be opened and recorded.
 - (b) **Step 2:** the remaining Tenders will be sorted out and those marked “**SUBSTITUTION (S)**” or “**MODIFICATION (M)**” of Tender will be linked with their corresponding Original Tender.
 - (c) **Step 3:** outer envelopes marked “**SUBSTITUTION (S)**” shall be opened. The inner envelopes containing the “**Substitution of Technical Offer (STO)**” and/or “**Substitution of Financial Offer (SFO)**” shall be exchanged for the corresponding envelopes being substituted, which are to be returned to the Tenderer unopened by the Procuring Entity at a later time immediately after opening of Technical Offers. Only the Substitution of Technical Offer, if any, shall be opened, read out, and recorded. Substitution of Financial Offer will remain unopened in accordance with ITT Sub Clause 48.1. No envelope shall be substituted unless the corresponding substitution notice contains a valid authorization to request the substitution and is read out and recorded at Technical Offer opening.
 - (d) **Step 4:** outer envelopes marked “**MODIFICATION (M)**” shall be opened. No Technical Offer and/or Financial Offer shall be modified unless the



corresponding modification notice contains a valid authorization to request the modification and is read out and recorded at the opening of Technical Offers. Only the Technical Offers, both Original as well as Modification, are to be opened, read out, and recorded at the opening. Financial Offers, both Original as well as Modification, will remain unopened in accordance with ITT Sub Clause 48.1.

- (e) **Step 5:** if so specified in this Tender Document, the envelopes marked "Alternative of Technical Offer (ATO)" shall be opened and read aloud with the corresponding Technical Offer and recorded.

48.6 Ensuring that only the correct (MTO), (STO), (ATO), (OTO) envelopes are opened, details of each Technical Offer will be dealt with as follows:

- (a) the Chairperson of the TOC will read aloud each Technical Offer and record in the Technical Offer Opening Sheet (TOOS):
- (i) the name and address of the Tenderer;
 - (ii) state if it is a withdrawn, modified, substituted or original Technical Offer;
 - (iii) any alternatives;
 - (iv) record the rejection of the Tender which submitted Technical Offer and Financial Offer together in one envelope.
 - (v) the presence or absence of any requisite Tender Security; and
 - (vi) such other details as the Procuring Entity, at its discretion, may consider appropriate.

(b) Only Technical Offer and alternatives read aloud at the Technical Offer Opening will be considered in evaluation.

(c) all pages of the original version of the Technical Offer, except for un-amended printed literature, will be initialled by members of the TOC. **Remember, No financial Offer shall be opened with Technical Offer.**

48.7 Upon completion of Technical Offer opening, all members of the TOC and the Tenderers or Tenderer's duly authorised representatives attending the Technical Offer opening shall sign by name, address, designation, the TOS, copies of which shall be issued to the Head of the Procuring Entity or an officer authorised by him or her and also to the members of the TOC and any authorised Consultants and, to the Tenderers immediately.

48.8 The omission of a Tenderer's signature on the record shall not invalidate the contents and effect of the record under ITT Sub Clause 48.7.

48.9 No Tender i.e., Technical or Financial Offer shall be rejected at the Tender opening stage except the LATE Tenders as stated in the ITT Clause 43.

49. Evaluation of Tenders

49.1 Technical Offers shall be examined and evaluated only on the basis of the criteria specified in the Tender Document.

49.2 **Tender Evaluation Committee (TEC)** shall examine, evaluate and compare Tenders that are responsive to the requirements of Tender Documents in order to identify the successful Tenderer.

50. Evaluation Process

50.1 TEC may consider a Tender Offer as responsive in the Evaluation, only if it is submitted in compliance with the mandatory requirements set out in the Tender Document. The evaluation process should begin immediately after Technical Offer opening following two steps:

- (a) Preliminary examination;



- (b) Technical examination and responsiveness.
51. Preliminary Examination
- 51.1 TEC shall examine the Technical Offers to confirm that all documentation as stated under ITT Clause 24 has been provided, to determine the completeness of each document submitted.
- 51.2 TEC shall confirm that the following documents and information have been provided in the Technical Offer. If any of these documents or information is missing, the Tender shall be considered rejected.
- (a) Tender Submission Letter;
 - (b) Written confirmation authorizing the signatory of the Tender to commit the Tenderer; and
 - (c) Valid Tender Security.
52. Technical Responsiveness and Technical Evaluation
- 52.1 TEC's determination of a Tender's responsiveness is to be based on the contents of the Technical itself without recourse to extrinsic evidence.
- 52.2 A responsive Tender is one that conforms in all respects to the requirements of the Tender Document without material deviation, reservation, or omission. A material deviation, reservation, or omission is one that:
- (a) affects in any substantial way the scope, quality, or performance of the Works and physical services specified in the Contract; or
 - (b) limits in any substantial way, or is inconsistent with the Tender Documents, the Procuring Entity's rights or the Tenderer's obligations under the Contract; or
 - (c) if rectified would unfairly affect the competitive position of other Tenderers presenting responsive Tenders.
- During the evaluation of Technical Offer, the following definitions shall apply:
- “**Deviation**” is a departure from the requirements specified in the Tender Document;
- “**Reservation**” is the setting of limiting conditions or withholding from complete acceptance of the requirements specified in the Tender Document; and
- “**Omission**” is the failure to submit part or all of the information or documentation required in the Tender Document.
- 52.3 If a Tender is not responsive to the mandatory requirements set out in the Tender Document, shall not subsequently be made responsive by the Tenderer by correction of the material deviation, reservation, or omission.
- 52.4 There shall be no requirement as to the minimum number of responsive Tenders.
- 52.5 TEC shall evaluate the aspects of the Tender submitted as stated under ITT Clauses 29, 30, 31 and 32 and, to confirm that all requirements specified in **Section 7: General Specifications and Section 8: Particular Specifications** of the Tender Document have been met without any material deviation, reservation or omission.
- 52.6 Provided that a Tender is responsive, TEC may request that the Tenderer submit the necessary information or documentation, within a reasonable period of time, to rectify nonmaterial nonconformities or omissions in the Technical Offer related to documentation requirements. Such omission shall not be related to any aspect of the rates of the Tender reflected in the Priced BOQ or any mandatory criteria. Failure of the Tenderer to comply with the request may result in the consideration of its Tender as non-responsive.



- 52.7 TEC may regard a Tender as responsive even if it contains:
- (a) minor or insignificant deviations which do not meaningfully alter or depart from the technical specifications, characteristics and commercial terms and conditions or other mandatory requirements set out in the Tender Document; or
 - (b) errors or oversights, that if corrected, would not alter the key aspects of the Technical Offers.
53. Clarification on Technical Offer
- 53.1 TEC may ask Tenderers for clarification of the Technical Offers, including breakdowns of unit rates, in order to facilitate the examination and evaluation of Technical Offers. The request for clarification by the TEC and the response from the tenderer shall be in writing, and Technical Offers clarifications which may lead to a change in the substance of the Technical Offers or in any of the key elements of the Technical Offers as stated under ITT Sub clause 52.2, will neither be sought nor be permitted.
- 53.2 Any request for clarifications by the TEC shall not be directed towards making an apparently non-responsive Tender responsive and reciprocally the response from the concerned Tenderer shall not be articulated towards any addition, alteration or modification to its Tender.
- 53.3 If a Tenderer does not provide clarifications of its Tender by the date and time, its Tender shall not be considered in the evaluation.
54. Restrictions on Disclosure of Information
- 54.1 Following the opening of Technical Offers until issuance of Notification of Award no Tenderer shall, unless requested to provide clarification to its Tender or unless necessary for submission of a complaint, communicate with the concerned Procuring Entity.
- 54.2 Tenderers shall not seek to influence in anyway, the examination and evaluation of the Tenders.
- 54.3 Any effort by a Tenderer to influence the Procuring Entity in its decision concerning the evaluation of Tenders, Contract awards may result in the non-responsiveness of its Tender as well as further action in accordance with Section 64 (5) of the Public Procurement Act, 2006.
- 54.4 All clarification requests shall remind Tenderers of the need for confidentiality and that any breach of confidentiality on the part of the Tenderer may result in their Tender being non-responsive.
55. Approval of Technical Offer
- 55.1 TEC shall prepare the Technical Offer Evaluation Report and shall directly submit the Evaluation Report to the **Head of the Procuring Entity (HOPE) or Authorized Officer for approval.**
56. Financial Offer Opening
- 56.1 After getting approval of the Technical Offer Evaluation Report, **Financial Offer (Envelope-02)** of only the Responsive Tenderers who have been determined as qualified to the requirements of the Technical Offer, shall be opened publicly, The Date, time and place of Financial Offer Opening shall be communicated to the Responsive Tenderers in writing by issuing a Financial Offer Opening notice not less than seven days before the opening.



56.2 Ensuring that only the correct MFO, SFO, OFO envelopes of the Responsive Tenderers shall be opened, in the presence of the Responsive Tenderer's representatives who choose to attend, on the date, time and at the place as notified by the Procuring Entity in accordance with ITT Clause 56.1. Details of each Technical Offer will be dealt with as follows:

- (a) the Chairperson of the Tender Evaluation Committee will read aloud each Financial Offer and record in the Financial Offer Opening Sheet (FOOS):
 - (i) the name and address of the Tenderer;
 - (ii) state if it is a modified, substituted or original Financial Offer;
 - (iii) the Tender Price;
 - (iv) the number of initialed corrections;
 - (v) any discounts; and
 - (vi) any other details as the Procuring Entity, at its discretion, may consider appropriate
- (b) only the discounts and alternatives read aloud and recorded at the Financial Offer Opening will be considered in Financial Offer Evaluation. No Tenders shall be rejected at the opening of the Financial Offer.
- (c) all pages of the original version of the Financial Offer, except for un-amended printed literature, will be initialled by members of the Tender Evaluation Committee.
- (d) The Procuring Entity shall, in writing, notify the Non-responsive Tenderers who have not been determined as qualified to the requirements of the Technical Offer and shall return their **Financial Offers (Envelope-02)** unopened after signing the Contract Award with the evaluated lowest responsive Tenderer.

57. Clarification on Financial Offer

- 57.1 TEC may ask Tenderers for clarification of their Financial Offers, about the breakdowns of unit rates, in order to facilitate the examination and evaluation of Financial Offers. The request for clarification by the TEC and the response from the Tenderer shall be in writing.
- 57.2 Changes in the Tender price shall not be sought or permitted, except to confirm the correction of arithmetical errors discovered by the TEC in the evaluation of the Tenders, as stated under ITT Sub Clause 58.1.
- 57.3 If a Tenderer does not provide clarifications of its Financial Offer by the date and time, its Tender shall not be considered in the evaluation.
- 57.4 Requests for clarifications on Financial Offers shall be duly signed only by the TEC Chairperson.



58. Correction of Arithmetical Errors
- 58.1 During the evaluation of Financial Offers, the TEC shall correct arithmetical errors on the following basis:
- (a) if there is a discrepancy between the unit price and the line item total price that is obtained by multiplying the unit price and quantity, the unit price will prevail and the line item total price shall be corrected, unless in the opinion of the TEC there is an obvious misplacement of the decimal point in the unit price, in which case the total price as quoted will govern and the unit price will be corrected; and
 - (b) if there is an error in a total corresponding to the addition or subtraction of subtotals, the subtotals shall prevail and the total shall be corrected; and
 - (c) if there is a discrepancy between words and figures, the amount in words shall prevail, unless the amount expressed in words is related to an arithmetic error, in which case the amount in figures shall prevail subject to (a) and (b) above.
- 58.2 TEC shall correct the arithmetic errors and shall promptly notify the concerned Tenderer(s). If the Tenderer that does not accept the correction of arithmetic errors, its Tender shall be considered non-responsive.
59. Financial Evaluation
- 59.1 TEC will evaluate each Financial Offer that has been opened duly.
- 59.2 To evaluate a Financial Offer, the TEC will consider the following:
- (a) the Tender price, excluding Provisional Sums and the provision, if any, for contingencies in the priced BOQ, but including Day work items;
 - (b) adjustments for correction of arithmetical errors, as stated under ITT Sub Clause 58.1;
 - (c) adjustments in order to take into consideration the unconditional discounts as stated under ITT Sub Clause 27.5 and 27.6, if any.
- 59.3 Variations, deviations, alternatives and other factors which are in excess of the requirements of the Tender Document or otherwise result in unsolicited benefits for the Procuring Entity will not be taken into account in Financial Offers evaluation.
- 59.4 The estimated effect of any price adjustment provisions under GCC Clause 69, applied over the period of execution of the Contract, will not be taken into account in Financial Offers evaluation.
- 59.5 If so indicated in the ITT Sub Clause 1.1, the Procuring Entity may award one or multiple lots to one Tenderer following the methodology specified in ITT Sub Clause 59.6.
- 59.6 To determine the lowest-evaluated lot/package the TEC will take into account:
- (a) the lowest-evaluated Tender for each lot;
 - (b) the resources sufficient to meet the qualifying criteria for the individual lot or aggregate of the qualifying criteria for the multiple lots;
 - (c) the price reduction on account of discount per lot/package as offered by the Tenderer in its Tender; and
 - (d) the Contract-award sequence that provides the optimum economic combination on the basis of least overall cost of the total Contract package taking into account any limitations due to constraints in Works or execution capacity determined in accordance with the tender capacity as stated in ITT Sub Clause 15.1(d) and post-qualification criteria as stated under ITT Clause 62.



- 59.7 TEC may recommend to increase the amount of the Performance Security above the amounts as stated under ITT Sub Clause 68.1 but not exceeding twenty-five (25) percent of the Contract Price, if in the opinion of TEC, it is found that the Tender is unbalanced as a result of front loading.
60. Price Comparison
- 60.1 TEC shall compare all responsive Financial Offers to determine the lowest-evaluated Tender, as stated under ITT Clause 59.
- 60.2 In the extremely unlikely event that there is a tie for the lowest evaluated price, the Tenderer with the superior past performance as stated in ITT Sub Clause 52.2 shall be selected.
- 60.3 In the event that there is a tie for the lowest price and none of the Tenderers has the record of past performance with the Procuring Entity as stated under ITT Sub Clause 60.2, then the Tenderer shall be selected, subject to firm confirmation through the Post-qualification process, after consideration as to whether the Tenderer has demonstrated in its Tender superior past performance with the other Procuring Entities or a more efficient work programme and work methodology.
- 60.4 The successful Tenderer as stated under ITT Sub Clause 60.1, 60.2 and 60.3 shall not be selected through lottery under any circumstances.
61. Negotiations
- 61.1 No negotiations shall be held during the Tender evaluation or award, with the lowest or any other Tenderer.
- 61.2 The Procuring Entity through the TEC may, however, negotiate with the lowest evaluated Tenderer with the objective to reduce the Contract Price by reducing the scope of works or a reallocation of risks and responsibilities, only when it is found that the lowest evaluated Tender is significantly higher than the official estimated cost; the reasons for such higher price being duly investigated and found realistic.
- 61.3 If the Procuring Entity decides to negotiate for reducing the scope of the requirements under ITT Sub Clause 61.2, it will be required to guarantee that the lowest Tenderer remains the lowest Tenderer even after the scope of work has been revised and shall further be ensured that the objective of the Procurement will not be seriously affected through this reduction.
- 61.4 In the event that the Procuring Entity decides because of a high Tender price to reduce the scope of the requirements to meet the available budget, the Tenderer is not obliged to accept the award and shall not be penalised in any way for un-accepting the proposed award.
62. Post-qualification
- 62.1 The determination on Post-Qualification shall be based upon an examination of the documentary evidence of the Tenderer's eligibility and qualifications submitted by the Tenderer, pursuant to ITT Clause 24, clarifications in accordance with ITT Clause 9 and the qualification criteria indicated in ITT Clause 12, 13, 14, 15, 16 and 17. Factors not included therein shall not be used in the evaluation of the Tenderer's qualification.
- 62.2 An Affirmative determination shall be a prerequisite for award of the contract to the Tenderer. A negative determination shall result in non-responsiveness of the tenderer's tender, in which event the procuring entity shall proceed to the next lowest evaluated Tender to make a similar determination of the tenderer's capabilities to perform the Contract satisfactory, if awarded.
- 62.3 TEC may verify information contained in the tender by visiting the premises of the Tenderer as a part of the post qualification process, if practical and appropriate.



63. **Procuring Entity's Right to Accept any or to Reject Any or All Tenders** 63.1 The Procuring Entity reserves the right to accept any Tender or to reject any or all the Tenders any time prior to contract award and, to annul the Procurement proceedings with prior approval of the Head of the Procuring Entity, any time prior to the deadline for submission of Tenders following specified procedures, without thereby incurring any liability to Tenderers, or any obligations to inform the Tenderers of the grounds for the Procuring Entity's action.
64. **Rejection of All Tenders** 64.1 The Procuring Entity may, in the circumstances as stated under ITT Sub Clause 64.2 reject all Tenders following recommendations from the TEC only after the approval of such recommendations by the Head of the Procuring Entity.
- 64.2 All Tenders can be rejected, if -
- (a) the price of the lowest evaluated Tender exceeds the official estimated cost, provided the estimate is realistic, subject to ITT Sub Clause 61.2; or
 - (b) there is evidence of lack of effective competition; such as non-participation by a number of potential Tenderers; or
 - (c) the Tenderers are unable to propose completion of the contract within the stipulated time in its Tender, though the stipulated time is reasonable and realistic; or
 - (d) all Tenders are non-responsive; or
 - (e) evidence of professional misconduct, affecting seriously the Procurement process, is established pursuant to Rule 127 of the Public Procurement Rules, 2008.
- 64.3 Notwithstanding anything contained in ITT Sub-Clause 64.2 Tenders may not be rejected if the lowest evaluated price is in conformity with the market price.
65. **Informing Reasons for Rejection** 65.1 Notice of the rejection will be given promptly within seven (7) working days of decision taken by the Procuring Entity to all Tenderers and, the Procuring Entity will, upon receipt of a written request, communicate to any Tenderer the reason(s) for its rejection but is not required to justify those reason(s).
- G. Contract Award**
66. **Award Criteria** 66.1 The Procuring Entity shall award the Contract to the Tenderer whose Tender is responsive to all the requirements of the Tender Document and that has been determined to be the lowest evaluated Tender, provided further that the Tenderer is determined to be Post-qualified in accordance with ITT Clause 62.
- 66.2 Tenderer will not be required, as a condition for award, to undertake responsibilities not stipulated in the Tender Documents, to change its price, or otherwise to modify its Tender.
67. **Notification of Award** 67.1 Prior to the expiry of the Tender Validity period and within one (1) week of receipt of the approval of the award by the Approving Authority, the Procuring Entity shall issue the Notification of Award (NOA) to the successful Tenderer.
- 67.2 The NOA, attaching the contract as per the sample (**Form PW3A-8**) to be signed, shall state:
- (a) the acceptance of the Tender by the Procuring Entity;
 - (b) the price at which the contract is awarded;
 - (c) the amount of the Performance Security and its format;
 - (d) the date and time within which the Performance Security shall be



furnished; and

(e) the date and time within which the Contract shall be signed.

- 67.3 The NOA shall be accepted by the successful Tenderer within seven (7) working days from the date of its issuance.
- 67.4 Until a formal contract is signed, the NOA will constitute a Contract, which shall become binding upon the furnishing of a Performance Security and the signing of the Contract by both parties.
68. Performance Security
- 68.1 Performance Security shall be provided by the successful Tenderer in BDT currency, of the amount as specified in the **TDS**.
- 68.2 Procuring Entity shall increase the amount of the Performance Security on the recommendation of TEC above the amounts as stated under ITT Sub Clause 59.7.
- 68.3 The proceeds of the Performance Security shall be payable to the Procuring Entity unconditionally upon first written demand as compensation for Contractor's failure to complete its obligations under the Contract.
- 68.4 In the event a Government owned enterprise as stated under ITT Sub Clause 5.10 is the successful Tenderer, Performance Security, as stated under ITT Sub Clause 68.1, shall not be required and, in lieu, there shall be Retention Money as specified in the **TDS**.
69. Form and Time Limit for Furnishing of Performance Security
- 69.1 Performance Security, as stated under ITT Clause 68, may be in the form of a Bank Draft, Pay Order or an irrevocable unconditional Bank Guarantee in the format (**Form PW3A-10**), without any alteration, issued by any scheduled Bank of Bangladesh acceptable to the Procuring Entity.
- 69.2 Within fourteen (14) days from the date of acceptance of the NOA but not later than the date specified therein, the successful Tenderer shall furnish the Performance Security for the due performance of the Contract in the amount as stated under ITT Sub Clauses 68.1 or 68.2.
70. Validity of Performance Security
- 70.1 Performance Security shall be required to be valid until a date twenty-eight (28) days beyond the Intended Completion Date as specified in Tender Document.
71. Authenticity of Performance Security
- 71.1 The Procuring Entity shall verify the authenticity of the Performance Security submitted by the successful Tenderer by sending a written request to the branch of the Bank issuing the Pay Order, Bank Draft or irrevocable unconditional Bank Guarantee in specified format.
72. Contract Signing
- 72.1 At the same time as the Procuring Entity issues the NOA, the Procuring Entity will send the draft Contract Agreement and all documents forming the Contract to the successful Tenderer.
- 72.2 Within twenty-eight (28) days of the issuance of the NOA, the successful Tenderer and the Procuring Entity shall sign the contract. In the event the successful Tenderer is a JV, all partners of that JV must sign.
- 72.3 Failure of the successful Tenderer to submit the Performance Security, as stated under ITT Sub Clause 68.1, or to sign the Contract, as stated under ITT Sub Clause 72.2, shall constitute sufficient grounds for the annulment of the award and forfeiture of the Tender Security. In that event the Procuring Entity may award the Contract to the next lowest evaluated responsive Tenderer, who is determined by the TEC to be qualified to perform the Contract satisfactorily.



73. **Publication of Notification of Award of Contract** 73.1 The NOA for Contract shall be notified by the Procuring Entity to the Central Procurement Technical Unit within seven (7) days of its issuance for publication in their website, and that notice shall be kept posted for not less than a month.
74. **Debriefing of Tenderers** 74.1 Debriefing of Tenderers by the Procuring Entity shall outline the relative status and weakness only of his or her Tender requesting to be informed of the grounds for not accepting the Tender submitted by him or her, without disclosing information about any other Tenderer.
- 74.2 In the case of debriefing, confidentiality of the evaluation process shall be maintained.
75. **Adjudicator** 75.1 The Procuring Entity proposes the person named in the TDS to be appointed as Adjudicator under the Contract, at an hourly fee and for those reimbursable expenses as specified in the TDS.
76. **Right to Complain** 76.1 Tenderer has the right to complain in accordance with the Public Procurement Act 2006 and the Public Procurement Rules, 2008.

Section 2. Tender Data Sheet



ITT Clause	Amendments of, and Supplements to, Clauses in the Instructions to Tenderers
A. General	
ITT 1.1	The Procuring Entity is: Bangladesh Petroleum Corporation. Executing agency: Eastern Refinery Limited. The Name of the Tender is: Renovation of Crude Oil Storage Tank No. 6101C. Tender Ref.: ER/DEV (M)-40(1)/2022 Lot No (s): Single Lot
ITT 3.1	The source of public funds is: Bangladesh Petroleum Corporation's (BPC) own fund
ITT 3.3	The name of the Development Partner is: Not Applicable.
ITT 5.1	Tenderers from the following countries are not eligible: Those countries with which Bangladesh has no diplomatic relationship.
ITT 5.13	Tenderers shall have the following up to date valid License: None.
ITT 6.1	Materials, Equipment and associated services from the following countries are not eligible: Those countries with which Bangladesh has no diplomatic relationship.
B. Tender Document	
ITT 8.2	The following are authorised agents/offices of the Procuring Entity for the purpose of issuing the Tender Document: <u>Agent's/office Name:</u> 1) Manager (Material Accounts) Address: Eastern Refinery Limited, North Patenga, Chattogram-4204, Bangladesh. 2) AGM (DLO) Address: ERL Liaison Office, YMCA Bhaban (2 nd Floor), 1/1, Pioneer Road, Kakrail, Dhaka-1000, Bangladesh.
ITT 9.1	For clarification of Tender purposes only, the Procuring Entity's address is: Attention: AGM (Development) Address: Eastern Refinery Limited, North Patenga, Chattogram-4204, Bangladesh. Telephone: 02333301261-7, Ext: 460. Fax No.: +8802333301269. E-mail address: agmdevelopment@erl.com.bd, md-office@erl.com.bd. and contact Procuring Entity within 05/09/2022.
ITT 10.1	A Pre-Tender meeting shall not be held.
C. Qualification Criteria	
ITT 14.1(a)	The minimum number of years of general experience of the Tenderer in the construction/reconstruction works as Prime Contractor or Subcontractor or Management Contractor shall be 5 (Five) years.



ITT 14.1(b)	The minimum specific experience as a Prime Contractor or Subcontractor or Management Contractor in construction/reconstruction/repair works of 1(One)/ more contract(s) of petroleum storage tank in govt./semi govt./autonomous body/reowned private institution(s) or similar organizations successfully completed within the last 5 (five) years, with a cumulative value of at least Tk. 1,15,00,000.00 (One crore and fifteen lac).																																														
ITT 15.1(a)	The required average annual construction turnover shall be greater than Tk. 3,00,00,000.00 (Three crore) over the best 03 (Three) years in the last 05 (Five) years.																																														
ITT 15.1(b)	The minimum amount of liquid assets i.e., working capital or credit line(s) of the Tenderers shall be Tk. 1,00,00,000.00 (One crore).																																														
ITT 15.1(d)	The minimum capacity shall be: Tk. 1,60,00,000.00 (One crore and sixty lac).																																														
ITT 16.1	The following key personnel shall have the qualifications and experience mentioned against each:																																														
	<table border="1"> <thead> <tr> <th data-bbox="590 694 662 772">No</th> <th data-bbox="662 694 821 772">Position</th> <th data-bbox="821 694 1109 772">Total Works Experience (Years)</th> <th data-bbox="1109 694 1505 772">Experience in similar works (Years)</th> </tr> </thead> <tbody> <tr> <td data-bbox="590 772 662 862">1</td> <td data-bbox="662 772 821 862">Site/project in charge</td> <td data-bbox="821 772 1109 862">5</td> <td data-bbox="1109 772 1505 862">2</td> </tr> <tr> <td data-bbox="590 862 662 952">2</td> <td data-bbox="662 862 821 952">Supervisor/ Foreman</td> <td data-bbox="821 862 1109 952">5</td> <td data-bbox="1109 862 1505 952">2</td> </tr> <tr> <td data-bbox="590 952 662 996">10</td> <td data-bbox="662 952 821 996">Welder (Gr-A)</td> <td data-bbox="821 952 1109 996">5</td> <td data-bbox="1109 952 1505 996">2</td> </tr> <tr> <td data-bbox="590 996 662 1041">6</td> <td data-bbox="662 996 821 1041">Fitter (Gr-A)</td> <td data-bbox="821 996 1109 1041">5</td> <td data-bbox="1109 996 1505 1041">2</td> </tr> <tr> <td data-bbox="590 1041 662 1086">7</td> <td data-bbox="662 1041 821 1086">Grinding man</td> <td data-bbox="821 1041 1109 1086">5</td> <td data-bbox="1109 1041 1505 1086">2</td> </tr> <tr> <td data-bbox="590 1086 662 1176">6</td> <td data-bbox="662 1086 821 1176">Sand blasting operator</td> <td data-bbox="821 1086 1109 1176">5</td> <td data-bbox="1109 1086 1505 1176">2</td> </tr> <tr> <td data-bbox="590 1176 662 1220">6</td> <td data-bbox="662 1176 821 1220">Painter</td> <td data-bbox="821 1176 1109 1220">5</td> <td data-bbox="1109 1176 1505 1220">2</td> </tr> <tr> <td data-bbox="590 1220 662 1265">2</td> <td data-bbox="662 1220 821 1265">Electrician</td> <td data-bbox="821 1220 1109 1265">5</td> <td data-bbox="1109 1220 1505 1265">2</td> </tr> <tr> <td data-bbox="590 1265 662 1355">10</td> <td data-bbox="662 1265 821 1355">Fitter/ Welder Helper</td> <td data-bbox="821 1265 1109 1355">5</td> <td data-bbox="1109 1265 1505 1355">2</td> </tr> <tr> <td data-bbox="590 1355 662 1417">30</td> <td data-bbox="662 1355 821 1417">Casual Labour</td> <td data-bbox="821 1355 1109 1417">5</td> <td data-bbox="1109 1355 1505 1417">2</td> </tr> </tbody> </table>	No	Position	Total Works Experience (Years)	Experience in similar works (Years)	1	Site/project in charge	5	2	2	Supervisor/ Foreman	5	2	10	Welder (Gr-A)	5	2	6	Fitter (Gr-A)	5	2	7	Grinding man	5	2	6	Sand blasting operator	5	2	6	Painter	5	2	2	Electrician	5	2	10	Fitter/ Welder Helper	5	2	30	Casual Labour	5	2		
No	Position	Total Works Experience (Years)	Experience in similar works (Years)																																												
1	Site/project in charge	5	2																																												
2	Supervisor/ Foreman	5	2																																												
10	Welder (Gr-A)	5	2																																												
6	Fitter (Gr-A)	5	2																																												
7	Grinding man	5	2																																												
6	Sand blasting operator	5	2																																												
6	Painter	5	2																																												
2	Electrician	5	2																																												
10	Fitter/ Welder Helper	5	2																																												
30	Casual Labour	5	2																																												



ITT 17.1

Tenderers shall own or have proven access to hire or lease of the major construction equipments, in full working order as follows :

Sl. No.	Equipment Type and Characteristics	Minimum Number Required
1	DC W/MC 400-600 Amps, 380V, 3 Phase, 50 Hz.	10
2	Gas cutter set and gas cylinders with safety device (Flash back arrestor for Oxygen and Acetylene cylinder from murex).	8
3	Complete Carbon Arc Gouging attachments.	2
4	Stationary electrode heater (Oven) for pre heating low hydrogen electrode up to 300°C before use with temperature control thermostat.	2
5	Hand carrying electrode heater of heating range 50°C to 150°C.	10
6	Plate lifting equipment, Crane/ Winch of capacity not less than 7M Ton for lifting of plate 45 ft above the ground (No diesel will be supplied for crane).	1
7	PSP	Sufficient nos.
8	Automatic plate bending m/c (electric operated)	Sufficient nos.
9	Scaffolding materials, preferably metallic as needed for working and painting at any position like wind girder, scale rider, railing, shell top etc.	Sufficient nos.
10	Different types of support to replace bottom, annular, roof, shell plate etc.	As required
11	Pump operated Hydraulic Jack of 50 MT capacities each	15
12	Shim plate	300
13	Wedge	300
14	Key plate	50
15	Blank nut	150
16	Sand blasting equipment (complete) with bucket, compressed air reservoir and air compressor of capacity 100 cfm at minimum 7 bar pressure.	2 sets
17	Vacuum test equipment (complete) with bucket, compressed air reservoir and air compressor of capacity 100 cfm at minimum 7 bar pressure.	1 set
18	MPT test equipments. Full test arrangements and submission of report,	1 set
19	X-ray equipment. Full test arrangement and submission of report	1set
20	Personnel safety equipments like helmet, safety shoe, safety belt, gloves, welding goggles, eye protection clear goggles etc.	Sufficient nos.
21	Wire rope, nylon rope of length not less than 50 M of different dia.	6 nos. of each size
22	Chain hoist of 2, 3 & 5 M Ton	4 nos. of each
23	Bitumen heating & carpeting equipments	As required
24	Other necessary auxiliary equipments	As required
25	Power supply panel as per drawing & list of accessories	2
26	Electrode E6013 & low hydrogen electrode E7016/E7018 (2.5, 3.2 & 4.0 mm) as per advice of Development department.	As required
27	Oxygen & Acetylene gas/LPG gas.	As required
28	Paint (from Berger paints BD Ltd. Or equivalent manufacturer) and structural materials (from BSRM or equivalent manufacturer) e.g., angle, channel, I-beam, GI & Brass sheet etc.	As required

ITT 18.1

The value of non-judicial stamp for execution of the Joint Venture Agreement shall be: **Not Applicable.**

ITT 18.2

Maximum number of partners in the JV shall be: **Not Applicable.**



	The minimum qualification requirements of Leading Partner, other Partner(s) and requirements by summation of a JV shall be as follows: Not Applicable.
ITT 19.4	The Nominated Subcontractor(s): None.
D. Tender Preparation	
ITT 24.2(k)	<p>The Tenderer shall submit with its Tender, the following documents in addition to ITT 24.2 (a-j):</p> <ul style="list-style-type: none">i) Tender Document purchase receipt (Original).ii) Photocopy of NID of Tenderer.iii) Up to date trade license for similar kind of works.iv) Vat registration certificate.v) Income tax clearance certificate.vi) Enlistment documents with govt., semi govt., autonomous bodies or similar organizations.vii) Ownership affidavit from any court of first class magistrate or Nationality certificate from any competent govt. authority.viii) Financial solvency certificate from any schedule bank of Bangladesh. Issue date of solvency certificate should not be earlier than six months from the date of submission of tender. <p style="text-align: center;">or,</p> <p style="text-align: center;">Letter of commitment for Bank's undertaking for Line of Credit.</p> <ul style="list-style-type: none">ix) Signed Original Tender document (except Section 6: Bill of Quantities if it is submitted with the financial offer).x) Signed copy of authorization/ownership of equipments related to tank renovation.xi) Any other information the Tenderer feels necessary to include.



ITT 24.3(d)	Tenderers shall submit with its Financial Offers the following additional documents: None . N.B.: Priced BOQ shall be submitted using Original/Photocopy form(s) furnished in Section 6: Bill of Quantities with the financial offer.
ITT 26.2	Alternative technical solutions for any parts of works will not be permitted.
ITT 27.8	The prices quoted by the Tenderers shall be fixed for the duration of the Contract.
ITT 31.1	The required Technical Proposal shall include the following additional information: None .
ITT 32.1(e)	The required information regarding claims under litigation shall be current or during the last 5 (Five) years.
ITT 32.1(i)	The required reports on the financial standing, such as profit and loss statements and audited balance sheet shall be for the best 3 (Three) years in the past 5 (Five) years.
ITT 33.1	The Tender Validity period shall be 120 (One hundred and twenty) days.
ITT 35.1	The amount of the Tender Security shall be Tk. 2,00,000.00 (Two lakh) in favour of Eastern Refinery Limited .
ITT 40.1	In addition to the original of the Technical offer, No copy shall be submitted.
ITT 40.2	In addition to the original of the Financial offer, No copy shall be submitted.
E. Tender Submission	
ITT 41.2(e)	The inner and outer envelopes of the Technical Offer shall bear the following additional identification marks: Attention: Mamshad Karim Anwar, Assistant General Manager (Development) Eastern Refinery Limited, North Patenga; Chattogram-4204; Bangladesh. Telephone: 8802333301261-7, Ext: 460 Fax No.: 8802333301269
ITT 41.4(e)	The inner and outer envelopes of the Financial Offer shall bear the following additional identification marks: Attention: Mamshad Karim Anwar, Assistant General Manager (Development) Eastern Refinery Limited, North Patenga; Chattogram-4204; Bangladesh. Telephone: 8802333301261-7, Ext: 460 Fax No.: 8802333301269
ITT 42.1	For Tender submission purposes , the Procuring Entity's address is: Attention: Mamshad Karim Anwar, Assistant General Manager (Development) Eastern Refinery Limited. Address: BPC Board Room, Bangladesh Petroleum Corporation (BPC); BSC Bhaban; Saltgola Road; P.O. Box 2050, Chattogram-4100; Bangladesh.



	The deadline for submission of Tenders is: Time & Date: 15:00 Hrs & 06 September' 2022.
ITT 42.4	The deadline for hand-delivering of the Tenders at the PRIMARY PLACE is: Address: BPC Board Room, Bangladesh Petroleum Corporation (BPC); BSC Bhaban; Saltgola Road; P.O. Box 2050, Chattogram-4100; Bangladesh. The deadline for submission of Tenders is: Time & Date: 15:00 Hrs & 06 September' 2022.
F. Tender Opening and Evaluation	
ITT 48.1	The Tender opening shall take place at: Address: BPC Board Room, Bangladesh Petroleum Corporation (BPC); BSC Bhaban; Saltgola Road; P.O. Box 2050, Chattogram-4100; Bangladesh. Time & Date: 15:15 Hrs & 06 September' 2022.
G. Contract Award	
ITT 68.1	The amount of Performance Security shall be 10 (ten) percent of the contract price.
ITT 68.4	The Retention Money shall be deducted: Not Applicable.
ITT 75.1	The Adjudicator proposed by the Procuring Entity is: BPC/ERL.

Section 3. General Conditions of Contract



A. General

1. Definitions

1.1 In the Conditions of Contract, which include Particular Conditions and these General Conditions, the following words and expressions shall have the meaning hereby assigned to them. Boldface type is used to identify the defined terms:

- (a) **Act** means The Public Procurement Act, 2006 (Act 24 of 2006).
- (b) **Adjudicator** is the expert appointed jointly by the Procuring Entity and the Contractor to resolve disputes in the first instance, as provided for in GCC Sub Clause 92.2.
- (c) **Approving Authority** means the authority which, in accordance with the Delegation of Financial Powers, approves the award of contract.
- (d) **Bill of Quantities (BOQ)** means the priced and completed Bill of Quantities forming part of the Contract defined in GCC Clause 59.
- (e) **Compensation Events** are those defined in GCC Clause 67.
- (f) **Competent Authority** means the authority that gives decision on specific issues as per delegation of administrative and/or financial powers.
- (g) **Completion Certificate** means the Certificate issued by the Project Manager as evidence that the Contractor has executed the Works and physical services in all respects as per design, drawing, specifications and Conditions of Contract.
- (h) **Completion Date** is the actual date of completion of the Works and physical services certified by the Project Manager, in accordance with GCC Clause 78.
- (i) **Contract Agreement** means the Agreement entered into between the Procuring Entity and the Contractor, together with the Contract Documents referred to therein, including all attachments, appendices, and all documents incorporated by reference therein to execute, complete, and maintain the Works.
- (j) **Contract Documents** means the documents listed in GCC Clause 6, including any amendments thereto.
- (k) **Contractor** means the Person under contract with the Procuring Entity for the execution of Works under the Rules and the Act as stated in the PCC.
- (l) **Contract Price** means the price payable to the Contractor as specified in the Contract Agreement, subject to such additions and adjustments thereto or deductions there from, for the execution, completion and maintenance of the Works in accordance with the provisions of the Contract.
- (m) **Contractor's Tender** is the completed Tender Document including the priced BOQ and the Schedules submitted by the Contractor to the Procuring Entity.
- (n) **Cost** means all expenditures reasonably incurred or to be incurred by the Contractor, whether on or off the Site, including overhead, taxes, duties, fees and such other similar levies including corresponding incidental charges and premiums for banking and



- insurances, as applicable.
- (o) **Day** means calendar day unless otherwise specified as working days.
 - (p) **Dayworks** means work carried out following the instructions of the Procuring Entity or the authorised Project Manager and is paid for on the basis of time spent by the Contractor's workers and equipment at the rates specified in the Schedules, in addition to payments for associated Materials and Plant.
 - (q) **Defect** is any part of the Works not completed in accordance with the Contract.
 - (r) **Defects Correction Certificate** is the certificate issued by the Project Manager upon correction of defects by the Contractor.
 - (s) **Drawings** include calculations and other information provided in Section 9 or as approved by the Project Manager for the execution and completion of the Contract.
 - (t) **Equipment** is the Contractor's apparatus, machinery, vehicles and other things required for the execution and completion of the Works and remedying any defects excluding Temporary Works and the Procuring Entity's Equipment (if any), Plant, Materials and any other things to form or forming part of the Permanent Works.
 - (u) **Force Majeure** means an event or situation beyond the control of the Contractor that is not foreseeable, is unavoidable, and its origins not due to negligence or lack of care on the part of the Contractor; such events may include, but not be limited to, acts of the Government in its sovereign capacity, wars or revolutions, fires, floods, epidemics, quarantine restrictions, and freight embargoes or more as included in GCC Clause 83;
 - (v) **GCC** means the General Conditions of Contract.
 - (w) **Government** means the Government of the People's Republic of Bangladesh.
 - (x) **Goods** mean the Contractor's Equipment, Materials, Plant and Temporary Works, or any of them as appropriate.
 - (y) **"Head of the Procuring Entity"** means the Secretary of a Ministry or a Division, the Head of a Government Department or Directorate; or the Chief Executive, or as applicable, Divisional Commissioner, Deputy Commissioner, Zilla Judge; or by whatever designation called, of a local Government agency, an autonomous or semi-autonomous body or a corporation, or a corporate body established under the Companies Act;
 - (z) **Intended Completion Date** is the date calculated from the Commencement Date as specified in the PCC, on which it is intended that the Contractor shall complete the Works and physical services as specified in the Contract and may be revised only by the Project Manager by issuing an extension of time or an acceleration order.
 - (aa) **Materials** means things of all kinds other than Plant intended to form or forming part of the Permanent Works, including the supply-only materials, if any, to be supplied by the Contractor under the Contract.
 - (bb) **Month** means calendar month.



- (cc) **Original Contract Price** is the Contract Price stated in the Procuring Entity's Notification of Award (Form PW3A-7) and further clearly determined in the PCC.
- (dd) **Permanent works** means the permanent works to be executed by the Contractor under the Contract.
- (ee) **PCC** means the Particular Conditions of Contract.
- (ff) **Plant** means the apparatus, machinery and other equipment intended to form or forming part of the Permanent Works, including vehicles purchased for the Procuring Entity and relating to the construction of the Works and physical services.
- (gg) **Procuring Entity** means a Procuring Entity having administrative and financial powers to undertake procurement of Works and physical services using public funds and is as named in the PCC who employs the Contractor to carry out the Works.
- (hh) **Project Manager** is the person named in the PCC or any other competent person appointed by the Procuring Entity and notified to the Contractor who is responsible for supervising the execution and completion of the Works and physical services and administering the Contract.
- (ii) **Provisional Sums means** amounts of money specified by the Procuring Entity in the BOQ which shall be used, at its discretion for meeting other essential expenditures under the Contract pursuant to GCC Sub Clause 75.
- (jj) **Retention Money** means the accumulated retention moneys which the Procuring Entity retains under GCC Clause 70.
- (kk) **Schedules** means the document(s) entitled schedules, completed by the Contractor and submitted with the Tender Submission Letter, as included in the Contract. Such document may include the data, lists and schedules of rates and/or prices.
- (ll) **Site** means the places where the Permanent Works are to be executed including storage and working areas and to which Plant and Materials are to be delivered, and any other places as may be specified in the PCC as forming part of the Site.
- (mm) **Site Investigation Reports** are those that were included in the Tender Document and are factual and interpretative reports about the surface and subsurface conditions at the Site.
- (nn) **Specification** means the Specification of the Works included in the Contract and any modifications or additions to the specifications made or approved by the Project Manager in accordance with the Contract.
- (oo) **Start Date** is the date defined in the PCC and it is the last date when the Contractor shall commence execution of the Works under the Contract.
- (pp) **Subcontractor** means a person or corporate body, who has a contract with the Contractor to carry out a part of the work in the Contract, which includes work on the Site.
- (qq) **Temporary Works** means all temporary works of every kind other than Contractor's Equipment required on the Site for the execution and completion of the Permanent Works and remedying of any defects.



- (rr) **Variation** means any change to the Works directly procured from the original Contract or to cover increases or decreases in quantities, including the introduction of new work items (non-Tendered items) that are either due to change of plans, design or alignment to suit actual field conditions, within the general scope and physical boundaries of the contract.
- (ss) **Works** means all works associated with the construction, reconstruction, site preparation, demolition, repair, maintenance or renovation of railways, roads, highways, or a building, an infrastructure or structure or an installation or any construction work relating to excavation, installation of equipment and materials, decoration, as well as physical services ancillary to works as detailed in the **PCC**, if the value of those services does not exceed that of the Works themselves.
- (tt) **Writing** means communication written by hand or machine duly signed and includes properly authenticated messages by facsimile or electronic mail.

2. Interpretation

2.1 In interpreting the GCC, singular also means plural, male also means female or neuter, and the other way around. Headings in the GCC shall not be deemed part thereof or be taken into consideration in the interpretation or construe of the Contract. Words have their normal meaning under the language of the Contract unless specifically defined.

2.2 Entire Agreement

The Contract constitutes the entire agreement between the Procuring Entity and the Contractor and supersedes all communications, negotiations and agreements (whether written or verbal) of parties with respect thereto made prior to the date of Contract Agreement; except those stated under GCC Sub Clause 6.1(j).

2.3 Non waiver

- (a) Subject to GCC Sub Clause 2.3(b), no relaxation, forbearance, delay, or indulgence by either party in enforcing any of the terms and conditions of the Contract or the granting of time by either party to the other shall prejudice, affect, or restrict the rights of that party under the Contract, neither shall any waiver by either party of any breach of Contract operate as waiver of any subsequent or continuing breach of Contract.
- (b) Any waiver of a party's rights, powers, or remedies under the Contract must be in writing, dated, and signed by an authorized representative of the party granting such waiver, and must specify the right and the extent to which it is being waived.

2.4 Severability

If any provision or condition of the Contract is prohibited or rendered invalid or unenforceable, such prohibition, invalidity or unenforceability shall not affect the validity or enforceability of any other provisions and conditions of the Contract.



- 2.5 Sectional completion
If sectional completion is specified in the **PCC**, references in the **GCC** to the Works, the Completion Date, and the Intended Completion Date apply to any section of the Works (other than references to the Completion Date and Intended Completion Date for the whole of the Works).
3. **Communications & Notices**
- 3.1 Communications between Parties (notice, request or consent required or permitted to be given or made by one party to the other) pursuant to the Contract shall be in writing to the addresses specified in the **PCC**.
- 3.2 A notice shall be effective when delivered or on the notice's effective date, whichever is later.
- 3.3 A Party may change its address for notice hereunder by giving the other Party notice of such change to the address.
4. **Governing Law**
- 4.1 The Contract shall be governed by and interpreted in accordance with the laws of the People's Republic of Bangladesh.
5. **Governing Language**
- 5.1 The Contract shall be written in English. All correspondences and documents relating to the Contract may be written in English or Bangla. Supporting documents and printed literature that are part of the Contract may be in another language, provided they are accompanied by an accurate translation of the relevant passages in English, in which case, for purposes of interpretation of the Contract, such translation shall govern.
- 5.2 The Contractor shall bear all costs of translation to the governing language and all risks of the accuracy of such translation.
6. **Documents Forming the Contract and Priority of Documents**
- 6.1 The following documents forming the Contract shall be interpreted in the following order of priority:
- (a) the signed Contract Agreement (**Form PW3A-9**);
 - (b) the Notification of Award (**PW3A-8**);
 - (c) the completed Tender and the Appendix to the Tender;
 - (d) the Particular Conditions of Contract;
 - (e) the General Conditions of Contract;
 - (f) the Technical Specifications;
 - (g) the General Specifications;
 - (h) the Drawings;
 - (i) the priced BOQ and the Schedules; and
 - (j) any other document listed in the **PCC** forming part of the Contract.
7. **Scope of Works**
- 7.1 The Works to be executed, completed and maintained shall be as specified in the BOQ, the General and Particular Specifications and Drawings.
- 7.2 Unless otherwise stipulated in the Contract, the Works shall include all such items not specifically mentioned in the Contract but that can be reasonably inferred from the Contract as being required for completion of the Works as if such items were expressly mentioned in the Contract.
8. **Assignment**
- 8.1 Neither the Contractor nor the Procuring Entity shall assign, in whole or in part, its obligations under the Contract.
9. **Eligibility**
- 9.1 The Contractor and its Subcontractor(s) shall have the nationality of a country other than that specified in the **PCC**.



- 9.2 All materials, equipment, plant, and supplies used by the Contractor in both permanent and temporary works and services supplied under the Contract shall have their origin in the countries except any specified in the **PCC**.
- 10.1 No fees, gratuities, rebates, gifts, commissions or other payments, other than those shown in the Tender or in the Contract, have been given or received in connection with the procurement process or in the Contract execution.
- 10.2 All materials, equipment, plant, and supplies used by the Contractor in both permanent and temporary works and services supplied under the Contract shall have their origin in the countries except any specified in the **PCC**.
- 11.1 The Contractor's and the Procuring Entity's personnel shall disclose all such confidential and other information as may be reasonably required in order to verify the Contractor's compliance with the Contract and allow its proper implementation.
- 11.2 Each of them shall treat the details of the Contract as private and confidential, except to the extent necessary to carry out their respective obligations under the Contract or to comply with applicable Laws. Each of them shall not publish or disclose any particulars of the Works prepared by the other Party without the previous agreement of the other Party. However, the Contractor shall be permitted to disclose any publicly available information, or information otherwise required to establish his qualifications to compete for other projects.
- 12.1 If the Contractor is a JV,
- (a) each partner of the JV shall be jointly and severally liable for all liabilities and ethical or legal obligations to the Procuring Entity for performance of the Contract;
- (b) the JV partners shall nominate the **Leading Partner** as **REPRESENTATIVE** being entrusted with the Contract administration and management at Site who shall have the authority to conduct all business including the receipt of payments for and on behalf of all partners of the JV;
- (c) If there is a dispute that results in legal action being taken in court then action will be taken against all partners of the JV, if they are available and, if only one partner is available, then that partner alone shall answer on behalf of all partners and, if the complaint lodged is proven, the penalty shall be applicable on that partner alone as whatever penalty all the partners would have received; provided that if the other partners of the JV subsequently become available before the legal action has been completed, the Procuring Entity shall have the right to take action against those other partners of that JV as well;
- (d) the composition or constitution and legal status of the JV shall not be altered without the prior approval of the Procuring Entity;
- (e) alteration of partners, **except the Leading partner**, shall only be allowed if any of them is found to be incompetent or has any serious difficulties which may impact the overall implementation of the Works, whereby the incoming partner shall require to possess qualifications higher than that of the outgoing partner;
- (f) if any of the partners of JV has been debarred from participating in any procurement activity due to corrupt, fraudulent, collusive or coercive practices and while in case, the Leading partner is found incompetent or has been debarred due to the same reasons stated herein the Contract shall be terminated pursuant to GCC Sub Clause 87.1(b).
10. **Gratuities / Agency Fees**
11. **Confidential Details**
12. **Joint Venture (JV)**



13. Possession of the Site 13.1 The Procuring Entity shall give possession of the Site or part(s) of the Site, to the Contractor on the date(s) stated in the **PCC**. If possession of a part of the Site is not given by the date stated in the **PCC**, the Procuring Entity will be deemed to have delayed the start of the relevant activities, and this will be a Compensation Event as stated under GCC Sub Clause 67.1(a).
14. Access to the Site 14.1 The Contractor shall allow the Project Manager and any person authorised by the Project Manager access to site and to any place where work in connection with the Contract is being carried out or is intended to be carried out.
15. Procuring Entity's Responsibilities 15.1 The Procuring Entity shall pay the Contractor, in consideration of the satisfactory progress of execution and completion of the Works and physical services, and the remedying of defects therein, the Contract Price or such other sum as may become payable under the provisions of the Contract at the times and in the manner prescribed by the Contract Agreement.
- 15.2 The Procuring Entity shall make its best effort to guide and assist the Contractor in obtaining, if required, any permit, licence, and approvals from local public authorities for the purpose of execution of the Works and physical services under the Contract.
16. Approval of the Contractor's Temporary Works 16.1 The Contractor shall submit Specifications and Drawings showing the proposed Temporary Works to the Project Manager, who is to approve them, if they comply with the Specifications and Drawings.
- 16.2 The Contractor shall be responsible for design of Temporary Works.
- 16.3 The Project Manager's approval shall not alter the Contractor's responsibility for design of the Temporary Works.
- 16.4 The Contractor shall obtain approval of third parties to the design of the Temporary Works, where required.
17. Contractor's Responsibilities 17.1 Contractor shall execute and complete the Works and remedy any defects therein in conformity in all respects with the provisions of the Contract Agreement.
18. Taxes and Duties 18.1 The Contractor shall be entirely responsible for all applicable taxes, custom duties, VAT, and other levies imposed or incurred inside and outside Bangladesh.
19. Contractor's Personnel 19.1 The Contractor shall employ the key personnel named in the Schedule of Key Personnel, as referred to in the **PCC**, to carry out the functions stated in the Schedule or other personnel approved by the Project Manager.
- 19.2 The Project Manager will approve any proposed replacement of key personnel only if their relevant qualifications and abilities are equal to or higher than those of the personnel named in the Schedule.
- 19.3 If the Project Manager asks the Contractor to remove a particular person who is a member of the Contractor's staff or work force from the Site, he or she shall state the reasons, and the Contractor shall ensure that the person leaves the Site within three (3) days and has no further connection with the work in the Contract.
20. Subcontracting 20.1 Subcontracting the whole of the Works by the Contractor shall not be permissible. The Contractor shall be responsible for the acts or defaults of any Subcontractor, his or her agents or employees, as if they were the acts or defaults of the Contractor.



- 20.2 The prior consent, in writing, of the Project Manager shall however be obtained for other proposed Subcontractor(s).
- 20.3 Nominated Subcontractor named in the Contract shall be entitled to execute the specific components of the Works stated in the **PCC**.
- 20.4 Subcontractors shall comply with the provisions of GCC Clause 38.
21. Other Contractors
- 21.1 Contractor shall cooperate and share the Site with other Contractors, public authorities, utilities, the Project Manager and the Procuring Entity between the dates given in the Schedule of other Contractors. The Contractor shall also provide facilities and services for them as described in the Schedule. The Procuring Entity may modify the Schedule of other Contractors, and shall notify the Contractor of any such modification.
22. Project Manager's Decisions
- 22.1 Except where otherwise specifically stated in the **PCC**, the Project Manager will decide Contractual matters between the Procuring Entity and the Contractor in its role as representative of the Procuring Entity.
23. Delegation
- 23.1 The Project Manager may delegate any of his duties and responsibilities to his representative except to the Adjudicator, after notifying the Contractor, and, may cancel any delegation, without retroactivity, after notifying the Contractor.
- 23.2 Any communications to the Contractor in accordance with such delegation shall have the same effect as if it was given by the Project Manager.
24. Instructions
- 24.1 The Contractor shall carry out all instructions of the Project Manager that comply with the applicable law.
25. Queries About the Contract Conditions
- 25.1 The Project Manager, on behalf of the Procuring Entity, will clarify queries on the Conditions of Contract.
26. Safety, Security and Protection of the Environment
- 26.1 The Contractor shall throughout the execution and completion of the Works and the remedying of any defects therein:
- (a) take all reasonable steps to safeguard the health and safety of all workers working on the Site and other persons entitled to be on it, and to keep the Site in an orderly state;
 - (b) provide and maintain at the Contractor's own cost all lights, guards, fencing, warning signs and watching for the protection of the Works or for the safety on-site; and
 - (c) take all reasonable steps to protect the environment on and off the Site and to avoid damage or nuisance to persons or to property of the public or others resulting from pollution, noise or other causes arising as a consequence of the Contractors methods of operation.
27. Working Hours
- 27.1 The Contractor shall not perform any work on the Site on the weekly holidays, or during the night or outside the normal working hours, or on any religious or public holiday, without the prior written approval of the Project Manager.
28. Welfare of Labourers
- 28.1 The Contractor shall comply with all the relevant labour Laws applicable to the Contractor's personnel relating to their employment, health, safety, welfare, immigration and shall allow them all their legal rights.



- 28.2 The Contractor, in particular, shall provide proper accommodation to his or her labourers and arrange proper water supply, conservancy and sanitation arrangements at the site for all necessary hygienic requirements and for the prevention of epidemics in accordance with relevant regulations, rules and orders of the government.
- 28.3 The Contractor, further in particular, shall pay reasonable wages to his or her labourers, and pay them in time. In the event of delay in payment the Procuring Entity may affect payments to the labourers and recover the cost from the Contractor.
- 29. Child Labour** 29.1 The Contractor shall not employ any child to perform any work that is economically exploitative, or is likely to be hazardous to, or to interfere with, the child's education, or to be harmful to the child's health or physical, mental, spiritual, moral, or social development in compliance with the applicable labor laws and other relevant treaties ratified by the government.
- 30. Discoveries** 30.1 Anything of historical or other interest or of significant value unexpectedly discovered on the Site shall be the property of the Procuring Entity. The Contractor shall notify the Project Manager of such discoveries and carry out the Project Manager's instructions for dealing with them.
- 31. Procuring Entity's and Contractor's Risks** 31.1 The Procuring Entity carries the risks that the Contract states are Procuring Entity's risks and the Contractor carries the risks that the Contract states are Contractor's risks.
- 32. Procuring Entity's Risks** 32.1 From the Start Date until the Defects Correction Certificate has been issued, the following are Procuring Entity's risks:
- (a) the risk of personal injury, death, or loss of or damage to property (excluding the Works, Plant, Materials, and Equipment), which are due to
 - i. use or occupation of the Site by the Works or for the purpose of the Works, which is the unavoidable result of the Works or
 - ii. negligence, breach of statutory duty, or interference with any legal right by the Procuring Entity or by any person employed by or Contracted to him except the Contractor.
 - (b) the risk of damage to the Works, Plant, Materials, and Equipment to the extent that it is due to a fault of the Procuring Entity or in the Procuring Entity's design, or due to war or radioactive contamination directly affecting the country where the Works are to be executed.
- 32.2 From the Completion Date until the Defects Correction Certificate has been issued, the risk of loss of or damage to the Works, Plant, and Materials is Procuring Entity's risk, except loss or damage due to:
- (a) a Defect which existed on the Completion Date;
 - (b) an event occurring before the Completion Date, which was not itself Procuring Entity's risk; or
 - (c) the activities of the Contractor on the Site after the Completion Date.
- 33. Contractor's Risks** 33.1 From the Start Date until the Defects Correction Certificate has been issued the risks of personal injury, death, and loss of or damage to property including without limitation, the Works, Plant, Materials, and Equipment, which are not Procuring Entity's risks are Contractor's risks.



34. Copyright

- 34.1 The copyright in all drawings, documents, and other materials containing data and information furnished to the Procuring Entity by the Contractor herein shall remain vested in the Contractor, or, if they are furnished to the Procuring Entity directly or through the Contractor by any third party, including Suppliers of materials, the copyright in such materials shall remain vested in such third party.
- 34.2 The Contractor shall not, except for the purposes of performing the obligations under the Contract, without the written permission of the Procuring Entity disclose or make use of any specification, plan, design and drawing, pattern, sample or information furnished by or on behalf of the Procuring Entity.

35. Limitation of Liability

- 35.1 Except in cases of criminal negligence or wilful misconduct:
- (a) the Contractor shall not be liable to the Procuring Entity, whether in Contract, tort, or otherwise, for any indirect or consequential loss or damage, loss of use, loss of production, or loss of profits or interest costs, provided that this exclusion shall not apply to any obligation of the Contractor to pay liquidated damages to the Procuring Entity; and
 - (b) the aggregate liability of the Contractor to the Procuring Entity, whether under the Contract, in tort or otherwise, shall not exceed the total Contract Price, provided that this limitation shall not apply to the cost of repairing or replacing defective Works, or to any obligation of the Contractor to indemnify the Procuring Entity with respect to patent infringement.

36. Insurance

- 36.1 The Contractor shall provide, in the joint names of the Procuring Entity and the Contractor, insurance cover from the Start Date to the end of the Defects Liability Period, in the amounts specified in the PCC for the following events which are due to the Contractor's risks:
- (a) loss of or damage to the Works, Plant, and Materials;
 - (b) loss of or damage to Equipment;
 - (c) loss of or damage to property (except the Works, Plant, Materials, and Equipment) in connection with the Contract; and
 - (d) personal injury or death.
- 36.2 The Contractor shall deliver policies and certificates of insurance to the Project Manager, for the Project Manager's approval, before the Start Date. All such insurances shall provide for compensation to be payable in the types and proportions required to rectify the loss or damage incurred.
- 36.3 If the Contractor does not provide any of the policies and certificates required, the Procuring Entity may affect the insurance which the Contractor should have provided and recover the premiums the Procuring Entity has paid from payments otherwise due to the Contractor or, if no payment is due, the payment of the premiums shall be a debt due.
- 36.4 Alternatives to the terms of insurance shall not be made without the approval of the Project Manager.
- 36.5 Both parties shall comply with conditions of the insurance policies.

37. Management and Progress

- 37.1 Either the Project Manager or the Contractor may require the other to attend a management and progress meeting. The business of such meeting shall be to review the progress and plans for remaining work and to deal



Meetings

with matters raised in accordance with the early warning procedure.

38. Corrupt, Fraudulent, Collusive or Coercive Practices

- 37.2 The Project Manager shall record the business of the meetings and provide copies of the record to those attending the meeting and to the Procuring Entity. The responsibility of the parties for actions to be taken shall be decided by the Project Manager either at the management and progress meeting or after the meeting, and stated in writing to all concerned.
- 38.1 The Government and the Development Partner requires that the Procuring Entity as well as the Contractor (including sub-contractors, agents, personnel, consultants and service providers), shall observe the highest standard of ethics during the implementation of procurement proceedings and the execution of contracts under public funds.
- 38.2 The Contractor (including sub-contractors, agents, personnel, consultants and service providers) shall permit the Government and/or the Development Partner to inspect the Contractor's accounts and records and other documents relating to the submission of Tender and contract performance, and to have them audited by auditors appointed by the Government and/or the Development Partner, if so required.
- 38.3 For the purposes of GCC Sub Clause 38.4, the terms set forth below as follows:
- (a) "corrupt practice" means offering, giving or promising to give, receiving, or soliciting either directly or indirectly, to any officer or employee of a Procuring Entity or other public or private authority or individual, a gratuity in any form; employment or any other thing or service of value as an inducement with respect to an act or decision or method followed by a Procuring Entity in connection with a Procurement proceeding or Contract execution;
 - (b) "fraudulent practice" means the misrepresentation or omission of facts in order to influence a decision to be taken in a Procurement proceeding or Contract execution;
 - (c) "collusive practice" means a scheme or arrangement between two (2) or more Persons, with or without the knowledge of the Procuring Entity, that is designed to arbitrarily reduce the number of Tenders submitted or fix Tender prices at artificial, non-competitive levels, thereby denying a Procuring Entity the benefits of competitive price arising from genuine and open competition;
 - (d) "coercive practice" means harming or threatening to harm, directly or indirectly, Persons or their property to influence a decision to be taken in the Procurement proceeding or the execution of the Contract, and this will include creating obstructions in the normal submission process used for Tenders; or
 - (e) "Obstructive practice" (applicable in case of Development Partner) means deliberately destroying, falsifying, altering or concealing of evidence material to the investigation or making false statements to investigators in order to materially impede an investigation into allegations of a corrupt, fraudulent, coercive or collusive practice; and/or threatening, harassing or intimidating any party to prevent it from disclosing its knowledge of matters relevant to the investigation or from pursuing the investigation.



38.4 Should any corrupt, fraudulent, collusive, coercive practice (or obstructive practice in case of Development Partner) of any kind, in competing for or in executing the Contract, is determined by the Procuring Entity, then the Procuring Entity may, upon giving 28 days' notice to the Contractor, terminate the Contractor's employment under the Contract and the provisions of Clause 87 shall apply as if such expulsion had been made under sub-clause 87.1 (Termination for Default).

38.5 If corrupt, fraudulent, collusive or coercive (or obstructive in case of Development Partners) practices of any kind determined by the Procuring Entity or the Development Partner against the Contractor alleged to have carried out such practices, the Procuring Entity and/or the Development Partner shall:

- (a) exclude the Contractor from further participation in the particular Procurement proceeding; or
- (b) declare, at its discretion, the Contractor to be ineligible to participate in further Procurement proceedings, either indefinitely or for a specific period of time; or
- (c) PE can debar the Contractor for a period of 1 (one) to 2 (two) years for the procurement of all procuring entities due to fundamental breach of contract.

38.6 The Contractor shall be aware of the provisions on corruption, fraudulence, collusion and coercion in Section 64 of the Public Procurement Act, 2006 and Rule 127 of the Public Procurement Rules, 2008 and in case of Development Partner financed contract, the Procurement Guidelines of the Development Partner.

B. Time Control

39. Commencement of Works

39.1 Except otherwise specified in the **PCC**, the Commencement Date shall be the date at which the following precedent conditions have all been fulfilled and the Project Manager's instruction recording the agreement of both Parties on such fulfilment and instructing to commence the Works is received by the Contractor:

- (a) signing of the Contract Agreement by both parties upon approval of the relevant authorities;
- (b) possession of the Site given to the Contractor as required for the commencement of the Works; and
- (c) receipt by the Contractor of the Advance Payment under GCC Clause 73 provided that the corresponding Bank Guarantee has been delivered by the Contractor, if any.

39.2 The Contractor shall commence the execution of the Works as soon as is reasonably practicable by the **Start Date** as specified in the GCC Sub Clause 1.1(oo) after the Commencement Date, and shall then proceed with the Works with due expedition and without delay.

40. Completion of Works

40.1 The Contractor shall carry out the Works in accordance with the Programme of Works submitted by the Contractor and as updated with the approval of the Project Manager as stated under GCC Clause 41 to complete them in all respects by the Intended Completion Date, as specified in the **PCC**.



- 41. Programme of Works**
- 41.1 Within the time stated in the **PCC**, the Contractor shall submit to the Project Manager for approval a Programme of Works showing the general methods, arrangements, order, and timing for all the activities in the Works. The programme may be in the form of an Implementation Schedule prepared in any software or other form acceptable to the Project Manager.
- 41.2 The Contractor shall submit to the Project Manager for approval of an updated Programme at intervals no longer than the period stated in the **PCC**. An update of the Programme shall be a Programme showing the actual progress achieved on each activity and the effect of the progress achieved on the timing of the remaining work, including any changes to the sequence of the activities.
- 41.3 If the Contractor does not submit an updated Programme of Works at the intervals as stated under GCC Sub Clause 41.2, the Project Manager may withhold an amount as stated in the **PCC** from the next payment certificate and continue to withhold this amount until the next due payment after the date on which the overdue Programme of Works has been submitted.
- 41.4 The Project Manager's approval of the Programme of Works shall not alter the Contractor's obligations. The Contractor may revise the Programme and submit it to the Project Manager again at any time for approval. A revised Programme shall show the effect of Variations and Compensation Events.
- 42. Pro-rata Progress**
- 42.1 The Contractor shall maintain Pro Rata progress of the Works. Progress to be achieved shall be pursuant to GCC Clause 41 and shall be determined in terms of the value of the works done.
- 43. Early Warning**
- 43.1 If at any time during performance of the Contract, the Contractor or its Subcontractors should encounter events, circumstances, conditions that may adversely affect the quality of the work, increase the original Contract Price or delay the execution of the Works, the Contractor shall promptly notify the Project Manager in writing of the delay, its likely duration, and its cause. As soon as practicable after receipt of the Contractor's notice, the Project Manager shall evaluate the situation, and the Contractor shall cooperate with the Project Manager in making and considering proposals for how the effect of such an event or circumstance can be avoided or reduced.
- 43.2 The Project Manager may require the Contractor to provide an estimate of the expected effect of the future event or circumstance on the original Contract Price and Completion Date. The Contractor shall provide the estimate and the Project Manager shall further proceed as soon as reasonably possible.
- 44. Extension of the Intended Completion Date**
- 44.1 The Contractor shall be entitled to an extension of the Intended Completion Date, if and to the extent that completion of the Works or any part thereof is or will be delayed by Compensation Events or a Variation or Extra Work Order.
- 44.2 If the Contractor considers itself to be entitled to an extension of the execution period as stated under GCC Sub Clause 44.1, the Contractor shall give notice, not later than twenty-eight (28) days after the Contractor became aware or should have become aware of the event or circumstance, to the Project Manager.



44.3 The Project Manager shall decide whether and by how much to extend the Intended Completion Date within twenty-one (21) days of the Contractor asking the Project Manager for a decision upon the effect of a Compensation Event or Variation and submitting full supporting information. If the Contractor has failed to give early warning of a delay or has failed to cooperate in dealing with a delay, the delay by this failure shall not be considered in assessing the extension of Intended Completion Date.

44.4 The Project Manager may extend the Intended Completion Date by twenty (20) percent of the original Contract time as stated under GCC Sub Clause 44.1, if a Compensation Event occurs or Variation Order or extra work Order issued which does not make it possible to complete the execution of works without incurring additional cost.

44.5 In the case an extension of the Intended Completion Date required under GCC Sub Clause 44.3 is or will be more than twenty (20) percent of the original Contract time, approval of the Head of the Procuring Entity or an officer authorized by him or her for the same shall be required to be obtained.

44.6 Except in case of Force Majeure, as provided under GCC Clause 83, a delay by the Contractor in the execution Works shall render the Contractor liable to the imposition of Liquidated Damages pursuant to GCC Clause 71, unless an extension of the Intended Completion Date is agreed upon, pursuant to GCC Clause 44.3.

45. Delays Caused by Authorities

45.1 the following conditions apply, namely:

- (a) the Contractor has diligently followed the procedures laid down by the relevant legally constituted public authorities,
- (b) these public authorities delay or disrupt the Contractor's work, and
- (c) the delay or disruption was unforeseeable;

Then this delay or disruption will be considered as a cause of delay under GCC Sub Clause 44.1.

45.2 The Project Manager shall notify the Contractor accordingly keeping the Procuring Entity posted.

46. Acceleration

46.1 When the Procuring Entity wants the Contractor to finish the Works before the Intended Completion Date, the Project Manager will obtain priced proposals for achieving the necessary acceleration from the Contractor. If the Procuring Entity accepts these proposals, the Intended Completion Date will be advanced accordingly and confirmed by both the Procuring Entity and the Contractor.

46.2 If the Procuring Entity accepts the Contractor's priced proposals for acceleration, they will be incorporated in the Contract Price and treated as a **Variation** under GCC Clause 61.

47. Delays Ordered by the Project Manager

47.1 The Project Manager may instruct the Contractor to delay the start or progress of any activity within the Works.

48. Suspension of Work

48.1 The Project Manager may at any time instruct the Contractor to suspend progress of part or all of the Works. During such suspension, the Contractor shall protect, store and secure such part or the Works against any deterioration, loss or damage.



- 49. Consequences of Suspension**
- 49.1 If the Contractor suffers delay and/or incurs cost from complying with the Project Manager's instructions under GCC Clause 48 and/or from resuming the work, the Contractor shall give notice to the Project Manager and shall be entitled subject to GCC Clause 91 to:
- (a) an extension of time for any such delay, if Completion is or will be delayed and
 - (b) payment of any such cost, which shall be included in the Contract Price.
- 49.2 After receiving this notice, the Project Manager shall proceed to agree or determine these matters.
- 49.3 The Contractor shall not be entitled to any extension of time for, or to any payment of the cost incurred in, making good the consequences of the Contractor's faulty design, workmanship or materials, or of the Contractor's failure to protect, store or secure in accordance with GCC Clause 48.

C. Quality Control

- 50. Execution of Works**
- 50.1 The Contractor shall construct, install and carry out the Works and physical services in accordance with the Specifications and Drawings as scheduled in GCC Clause 6.
- 51. Examination of Works before covering up**
- 51.1 All works under the Contract shall at all times be open to examination, inspection, measurements, testing and supervision of the Project Manager, and the Contractor shall ensure presence of its representatives at such actions provided proper advance notice is given by the Project Manager.
- 51.2 No part of the Works shall be covered up or put out of sight without the approval of the Project Manager. The Contractor shall give notice in writing to the Project Manager whenever any such part of the Works is ready for examination and, the Project Manager shall attend to such examination without unreasonable delay.
- 52. Identifying Defects**
- 52.1 Project Manager shall check the works executed by the Contractor and notify the Contractor of any Defects found. Such checking shall not relieve the Contractor from his or her obligations. The Project Manager may also instruct the Contractor to search for a Defect and to uncover and test any work that the Project Manager considers may have a Defect.
- 53. Testing**
- 53.1 If the Project Manager instructs the Contractor to carry out a test not specified in the Specification to check whether any work has a Defect and the test shows that it does, the Contractor shall pay for the test and any samples. If there is no Defect, the test shall be a Compensation Event pursuant to GCC Sub Clause 67.
- 54. Rejection of Works**
- 54.1 If, as a result of an examination, inspection, measurement or testing, of Works it is found to be defective or otherwise not in accordance with the Contract, the Project Manager may reject the Works by giving notice to the Contractor, with reasons. The Contractor shall then promptly make good the defect and ensure that the rejected Works subsequently complies with the Contract.



- 55. Remedial Work**
- 55.1 Notwithstanding any test or certification, the Project Manager may instruct the Contractor to:
- (a) remove from the Site and replace any Plant or Materials which is not in accordance with the Contract,
 - (b) remove and re-execute any other work which is not in accordance with the Contract, and
 - (c) execute any work which is urgently required for the safety of the Works, whether because of an accident, unforeseeable event or otherwise.
- 55.2 The Contractor shall comply with the instruction issued under GCC Sub Clause 55.1 within a reasonable time, which shall be specified in the instruction, or immediately if urgency is specified under GCC Sub Clause 55.1(c).
- 55.3 If the Contractor fails to comply with the instruction issued under GCC Sub Clause 55.2, the Procuring Entity shall be entitled to employ and pay other persons to carry out the work. Except to the extent that the Contractor would have been entitled to payment for the work, the Contractor shall be liable to pay all such costs arising from this failure.
- 56. Correction of Defects**
- 56.1 The Project Manager shall give notice to the Contractor, with a copy to the Procuring Entity and others concerned, of any Defects before the end of the Defects Liability Period, which begins at Completion Date, and is defined in the PCC. The Defects Liability Period shall be extended for as long as Defects remain to be corrected.
- 56.2 Every time notice of a Defect is given, the Contractor shall correct the notified Defect within the length of time specified by the Project Manager's notice.
- 57. Uncorrected Defects**
- 57.1 If the Contractor has not corrected a Defect within the time specified in the Project Manager's notice, the Project Manager shall assess the cost of having the Defect corrected by it, and the Contractor shall remain liable to pay the expenditures incurred on account of correction of such Defect.
- D. Cost Control**
- 58. Contract Price**
- 58.1 The Contract Price shall be as specified in the Contract Agreement subject to any additions and adjustments thereto, or deductions therefrom, as may be made pursuant to Contract.
- 59. Bill of Quantities (BOQ)**
- 59.1 The Bill of Quantities (BOQ) shall contain priced items for the construction, installation, testing, and commissioning work to be done by the Contractor.
- 59.2 The BOQ is used to calculate the Contract Price. The Contractor is paid for the quantity of the work done at the rate in the BOQ for each item.
- 59.3 Items of works quantified in the BOQ for which no rates have been quoted shall be deemed covered by the amounts at rates of other items in the Contract and, shall under no circumstances be paid for, by the Procuring Entity.
- 60. Changes in the Quantities and Unit Rate**
- 60.1 If the final quantity of the work done for any particular item in the BOQ increases by more than twenty-five (25) percent and, such increase in quantity of that particular item alone concurrently causes the original Contract Price to exceed by more than one (1) percent, the Project Manager shall adjust the unit rate of the item to allow for the change.



60.2 If requested by the Project Manager, the Contractor shall provide the Project Manager with a detailed cost breakdown of any rate in the BOQ.

61. Issue of Variation or Extra Work Order

61.1 The Project Manager may issue a **Variation Order** to the Contractor to cover increase or decrease in quantities, including the introduction of new work items (non-Tendered items) that are either due to change of plans, design or alignment to suit actual field conditions, within the general scope and physical boundaries of the contract.

61.2 The Project Manager may issue an **Extra Work Order** to cover the introduction of such new works necessary for the completion, improvement or protection of the original works which were not included in the original contract, on the grounds where there are subsurface or latent physical conditions at the site differing materially from those indicated in the contract, or where there are duly unknown physical conditions at the site of an unusual nature differing materially from those usually encountered and generally recognized as inherent in the work or character provided for in the Contract.

61.3 The Project Manager deems it necessary that a Variation or Extra Work Order should be issued, he or she shall prepare the proposed order, the necessary plans, his or her computations as to the quantities of the additional Works involved per item indicating the specific locations where such Works are needed, the date of his or her inspections and investigations thereon, and the log book thereof, and a detailed estimate of the unit cost of such items of work as stated under GCC Clause 62, together with his or her justifications for the need of such Variation or Extra Work Order, and shall submit the same to the Approving Authority. Any Amend to the contract that happens within the approved BOQ items and doesn't change the contract price shall be approved by the HOPE or delegated officer.

61.4 The Head of the Procuring Entity may, in exceptions to the GCC Sub Clause 61.3 and subject to the availability of funds, in the event of extreme emergency and when time is of the essence, authorize the immediate start of work under any Variation or Extra Work Order; provided that the cumulative increase in the value of Works not yet duly approved exceeded ten (10) percent of the adjusted original Contract Price.

61.5 Increase or decrease in the quantities of any item of work included in the BOQ for the reasons other than those stated under GCC Sub Clause 61.1 and 61.2, in particular for field level actual measurements under this contract (admeasurements), not necessarily however, shall constitute a **Variation**.

61.6 All Variations and Extra work orders under the Contract shall be included in the updated Programme of Works produced by the Contractor.

62. Costing of Variation Orders or Extra Work Orders

62.1 The Contractor shall provide the Project Manager with a quotation for carrying out the Variation when requested to do so by the Project Manager. The Project Manager shall assess the quotation, which shall be given within seven (7) working days of the request or within any longer period stated by the Project Manager and before the Variation is ordered.



62.2 If the item of work in the Variation corresponds to an item of work in the BOQ and if, in the opinion of the Project Manager, the increased quantity and cost of the works of that particular item does not concurrently cause to exceed the limit stated in GCC Sub Clause 60.1, the same unit rate in the BOQ shall be used to calculate the cost of the Variation. If the item of work in the Variation does not correspond to an item in the BOQ, the unit rates for the new items of works shall be determined based on (i) the direct unit costs used in the original Contract for other items (e.g. unit cost of cement, steel bar, labour rate, equipment rental, etc) as indicated in the Contractor's price breakdown of the cost estimate, if available or (ii) fixed prices acceptable to both, the Procuring Entity and the Contractor, based on market prices. The direct cost of the new work items based on (i) or (ii) stated herein shall then be combined with the mark-up factor (i.e., profit, overhead and VAT) used by the Contractor in its Tender to determine the unit rate of the new items of work.

62.3 If the Contractor's quotation is found to be unreasonable, the Project Manager may order the Variation and make a change to the Contract Price, which shall be based on the Project Manager's own forecast of the effects of the Variation on the Contractor's costs.

62.4 The Contractor shall not be entitled to additional payment for costs that could have been avoided by giving early warning under GCC Sub Clause 43.1.

62.5 The time for processing of a Variation and an Extra Work Order from its preparation to approval shall not exceed thirty (30) working days.

63. Cash Flow Forecasts

63.1 When the Programme of Works is updated under GCC Sub Clause 41.2, the Contractor shall provide the Project Manager with an updated cash flow forecast.

64. Payment Certificates

64.1 The basis for payment certificates shall be BOQ used to determine the Contract Price.

64.2 The Contractor shall submit to the Project Manager monthly statements of the estimated value of the works executed less the cumulative amount certified previously.

64.3 The Project Manager shall check the Contractor's monthly statement and certify the amount to be paid to the Contractor.

64.4 The value of work executed shall be determined by the Project Manager.

64.5 The value of work executed may also include the valuation of Variations or Extra Work Orders, Certified Dayworks and Compensation Events.

64.6 The Project Manager may exclude any item certified in a previous certificate or reduce the proportion of any item previously certified in any certificate in the light of later information.

65. Payments to the Contractor

65.1 Payments shall be adjusted for deductions for advance payments and retention. The Procuring Entity shall pay the Contractor the amounts certified by the Project Manager within twenty-eight (28) days of the date of each certificate after due adjustments for deductions for advance payments, retention and any other additions or deductions which may have become due under the Contract or otherwise, including those under GCC Clause 91.

65.2 Payments for Works under Variation Orders or Extra Work Orders satisfactorily accomplished pursuant to GCC Sub Clause 61 may be made



only after approval of the same by the Approving Authority or next higher, as appropriate..

65.3 Payments due to the Contractor in each certificate shall be made into the Bank Account, in any scheduled Bank of Bangladesh, of the legal title of the Contract specified in the **PCC**, nominated by the Contractor in the currency specified in the Contract.

66. Delayed Payment

66.1 If the Procuring Entity makes a late payment, the Contractor shall be paid interest on the late payment in the next payment at the rate as specified in the **PCC**. Interest shall be calculated from the date by which the payment should have been made up to the date when the late payment is made.

66.2 If an amount certified is increased in a subsequent certificate as a result of an award by the Adjudicator or an Arbitrator, the Contractor shall be paid interest upon the delayed payment as set out in this clause. Interest shall be calculated from the date upon which the increased amount would have been certified in the absence of dispute.

67. Compensation Events

67.1 The following shall be Compensation Events:

- (a) The Procuring Entity does not give access to or possession of the Site or part of the Site by the Site Possession Date stated in the GCC Sub Clause 13.1;
- (b) The Procuring Entity modifies the Schedule of other Contractors in a way that affects the works of the Contractor under the Contract;
- (c) The Project Manager orders a delay or does not issue Drawings, Specifications, or instructions required for execution of the Works on time;
- (d) The Project Manager instructs the Contractor to uncover or to carry out additional tests upon work, which is then found to have no Defects;
- (e) The Project Manager unreasonably does not approve a subcontract to be let, if applicable;
- (f) Ground conditions are substantially more adverse than could reasonably have been assumed before issuance of the Notification of Award from the information issued to Tenderers (including the Site Investigation Reports), from information available publicly and from a visual inspection of the Site; Other Contractors, public authorities, utilities, or the Procuring Entity do not work within the dates and other constraints stated in the Contract, and they cause delay or extra cost to the Contractor;
- (g) The advance payment is delayed;
- (h) The effects on the Contractor of any of the Procuring Entity's Risks;
- (i) The Project Manager unreasonably delays issuing a Completion Certificate;
- (j) A situation of Force Majeure has occurred, as defined in GCC Clause 83; and
- (k) Other Compensation Events described in the Contract or determined by the Project Manager in the **PCC** shall apply.



- 67.2 If a Compensation Event would cause additional cost or would prevent the work being completed before the Intended Completion Date, the Contract Price shall be increased and/or the Intended Completion Date shall be extended. The Project Manager shall decide whether and by how much the Contract Price shall be increased and whether and by how much the Intended Completion Date shall be extended, only on justifiably acceptable grounds duly recorded.
- 67.3 As soon as the Contractor has provided information demonstrating the effect of each Compensation Event upon the Contractor's forecast cost, the Project Manager shall assess it, and the Contract Price shall be adjusted accordingly. If the Contractor's forecast is deemed unreasonable, the Project Manager shall adjust the Contract Price based on the Project Manager's own forecast. The Project Manager will assume that the Contractor will react competently and promptly to the event.
- 67.4 The Contractor shall not be entitled to compensation to the extent that the Procuring Entity's interests are adversely affected by the Contractor not having given early warning or not having cooperated with the Project Manager.
68. Adjustments for Changes in Legislation
- 68.1 Unless otherwise specified in the Contract, if between the date twenty-eight (28) days before the submission of Tenders for the Contract and the date of the last Completion Certificate, any law, regulation, ordinance, order or bylaw having the force of law is enacted, promulgated, abrogated, or changed in Bangladesh (which shall be deemed to include any change in interpretation or application by the competent authorities) that subsequently affects the Completion Date and/or the Contract Price, then such Completion Date and/or Contract Price shall be correspondingly increased or decreased, to the extent that the Contractor has thereby been affected in the performance of any of its obligations under the Contract.
- 68.2 The Project Manager shall adjust the Contract Price on the basis of the change in the amount of taxes, duties, and other levies payable by the Contractor, provided such changes have not already been accounted for in the price adjustment as defined in GCC Clause 69 and/or reflected in the Contract Price.
69. Price Adjustment
- 69.1 Prices shall be adjusted for fluctuations in the cost of inputs only if provided for in the PCC. If so provided, the amounts as certified in each payment certificate, before deducting for Advance Payment, shall be adjusted by applying the respective price adjustment factor to the payment amount. The formulae indicated below applies:
- $$P = A + B (I_m / I_o)$$
- where:
- P** is the adjustment factor
- A** and **B** are Coefficients specified in the PCC, representing the nonadjustable and adjustable portions, respectively, of the Contract; and
- I_m** is the Index during the month the work has been executed and
- I_o** is the Index prevailing twenty-eight (28) days prior to the deadline for submission of Tender.

The Indexes to be used is as published by the Bangladesh Bureau of Statistics (BBS) on a monthly basis. In case not available, then other countries or authorities of the sources mentioned in **Appendix to the**



Tender may be used.

- 70. Retention Money**
- 70.1 The Procuring Entity may retain from each progressive payment due to the Contractor at the percentage specified in the **PCC** until completion of the whole of the Works under the Contract.
- 70.2 On completion of the whole of the Works, the first half of the total amount retained under GCC Sub Clause 70.1 shall be returned to the Contractor and the remaining second half after the Defects Liability Period has passed and the Project Manager has certified in the form of **Defects Corrections Certificate**.
- 70.3 On completion of the whole of the Works, the Contractor may substitute an irrevocable unconditional Bank Guarantee from any scheduled Bank of Bangladesh, in the format as specified (**Form PW3A-12**), without any alteration, acceptable to the Procuring Entity for the second half of the retention money as stated under GCC Sub Clause 70.2.
- 71. Liquidated Damages**
- 71.1 Except as provided under GCC Sub Clause 83, if the Contractor fails to complete the Works and physical services within the Intended Completion Date or extended Intended Completion Date, the Procuring Entity shall, as Liquidated Damages, deduct from the Contract Price, a sum at the percent-rate per day of delay as specified in the **PCC**, of the contract value of the uncompleted works or part thereof completed after the Intended Completion Date or extended Intended Completion Date, as applicable. The total amount of Liquidated Damages or Delay Damages shall not exceed the amount specified in the **PCC**. The Procuring Entity may deduct Liquidated Damages from payments due to the Contractor. Payment of Liquidated damages shall not affect the Contractor's liabilities.
- 71.2 If the Intended Completion Date is extended after Liquidated Damages have been paid, the Project Manager shall correct any overpayment of liquidated damages by the Contractor by adjusting the next payment certificate.
- 72. Bonus**
- 72.1 The Contractor shall be paid a Bonus calculated at the percent-rate per day **if stated in the PCC** for each day (less any days for which the Contractor is paid for acceleration) that the Completion of the whole of the Works is earlier than the Intended Completion Date. The Project Manager shall require certifying that the Works are complete, although they may not have fallen due to being complete as per approved updated Programme of Works.
- 73. Advance Payment**
- 73.1 The Procuring Entity shall make advance payment, if so specified in the **PCC**, to the Contractor in the amounts and by the dates specified in the **PCC** against an irrevocable unconditional Bank Guarantee issued by any scheduled Bank of Bangladesh in the format as specified (**Form PW3A-11**), without alteration, and acceptable to the Procuring Entity of an amount equal to the advance payment. The Guarantee shall remain effective until the advance payment has been amortized, but the amount of the Guarantee shall be progressively reduced by the amounts amortized by the Contractor. Interest will not be charged on the advance payment.
- 73.2 The Contractor shall use the advance payment only to pay for Equipment, Plant, Materials, and mobilization expenses required specifically for execution of the Contract. The Contractor shall demonstrate that advance payment has been used for such specific purposes by supplying copies of invoices or other documents to the Project Manager.



73.3 The advance payment shall be amortized by deducting at proportionate rate from payments otherwise due to the Contractor, following the schedule of completed percentages of the Works as specified in the PCC. No account shall be taken of the advance payment or its amortization in assessing valuations of work done, Variations, price adjustments, Compensation Events, Bonuses, or Liquidated Damages.

73.4 If the amortization of advance payment has not been completed by twenty-eight (28) days prior to the expiry date of the Guarantee stated under GCC Sub Clause 73.1, the Contractor shall correspondingly extend the validity of the Guarantee for a period so long the advance payment is fully amortized. The Bank Guarantee for advance payment shall be released when the same has been fully amortized.

74. Performance Security

74.1 The Procuring Entity shall notify the Contractor of any claim made against the Bank issuing the Performance Security.

74.2 The Procuring Entity may claim against the security if any of the following events occurs for fourteen (14) days or more.

(a) The Contractor is in breach of the Contract and the Procuring Entity has duly notified him or her ; and

(b) The Contractor has not paid an amount due to the Procuring Entity and the Procuring Entity has duly notified him or her.

74.3 In the event as stated under GCC Sub Clause 74.2, the Contractor is liable to pay compensation under the Contract amounting to the full value of the security or more, the Procuring Entity may call the full amount of the security.

74.4 The Performance Security furnished at the time of signing of the Contract Agreement shall be substituted, after the issuance of certificate of Completion of works by the Project Manager, by a new Security covering fifty (50) percent amount of the Performance Security to cover the Defects Liability Period.

74.5 If there is no reason to call the security, the security shall be discharged by the Procuring Entity and returned to the Contractor after the Defects Liability period has passed and the Project Manager has certified in the form of Defects Corrections Certificates and the Procuring Entity shall not make any claim under the security, except for amounts to which the Procuring Entity is entitled under this Contract. In the event this Contract is significantly below the updated official estimated cost or unbalanced as a result of front loading, the Procuring Entity shall call the full amount of the security in the circumstances stated under GCC Sub Clause 74.3.

75. Provisional Sums

75.1 Provisional Sums shall only be used, in whole or in part, in accordance with the Project Manager's instructions.

75.2 Plants, Materials or Services to be purchased by the Contractor under the provisions of GCC Sub Clause 75.1 from Nominated Subcontractor(s) or for meeting the other expenditures under the Contract, and for which there shall be included in the Contract price, the actual amounts paid or due to be paid by the Contractor, and a sum for profit, overhead and VAT, as applicable, calculated as a percentage of these actual amounts by applying the relevant percentage rate as specified in the PCC.



- 76. Dayworks**
- 76.1 If applicable, the Dayworks rates in the Contractor's Tender shall be used for small additional amounts of work only when the Project Manager has given written instructions in advance for additional work to be paid for in that way.
- 76.2 All works to be paid for as Dayworks shall be recorded by the Contractor on forms approved by the Project Manager. Each completed form shall be certified and signed by the Project Manager within seven (7) days of the works being done.
- 76.3 The Contractor shall be paid for Dayworks subject to obtaining signed Dayworks forms.
- 77. Cost of Repairs to Loss or Damages**
- 77.1 Loss or damage to the Works or Materials to be incorporated in the Works between the Start Date and the end of the Defects Liability Period shall be remedied by the Contractor at the Contractor's own cost, if the loss or damage arises from the Contractor's acts or omissions.
- E. Completion of Contract**
- 78. Completion**
- 78.1 The Contractor shall apply by notice to the Project Manager for issuing a Completion Certificate of the Works, and the Project Manager shall do so upon deciding that the work is completed.
- 79. Taking Over**
- 79.1 The Procuring Entity shall take over the Site and the Works within seven (7) days of the Project Manager's issuing a certificate of Completion.
- 80. Amendment to Contract**
- 80.1 The amendment to Contract shall generally include extension of time to the Intended Completion Date, increase or decrease in original Contract Price and any other changes acceptable under the conditions of the Contract.
- 80.2 The Procuring Entity shall amend the Contract, incorporating the changes approved, in accordance with the Delegation of Financial Power or Sub-delegation thereof and, introduced to the original terms and conditions of the Contract.
- 81. Final Account**
- 81.1 The Contractor shall submit with a detailed account of the total amount that the Contractor considers payable under the Contract to the Project Manager before the end of the **Defects Liability Period**.
- 81.2 The Project Manager shall certify the **Final Payment** within fifty six (56) days of receiving the Contractor's account if the payable amount claimed by the Contractor is correct and the corresponding works are completed.
- 81.3 If it is not, the Project Manager shall issue within fifty six (56) days a **Defects Liability Schedule** that states the scope of the corrections or additions that are necessary.
- 81.4 If the **Final Account of Works** submitted under GCC Sub Clause 81.1 is unsatisfactory even after it has been resubmitted, the Project Manager shall decide on the amount payable to the Contractor and issue a payment certificate.
- 82. As-built Drawings and Manuals**
- 82.1 If "As Built" Drawings and/or operating and maintenance manuals are required, the Contractor shall supply them by the dates stated in the **PCC**.
- 82.2 If the Contractor does not supply the Drawings and/or Manuals by the dates specified in GCC Sub Clause 82.1, or they do not receive the Project Manager's approval, the Project Manager shall withhold a nominal amount specified in the **PCC** from payments due to the Contractor.



83. Force Majeure

- 83.1 Majeure may include, but is not limited to, exceptional events or circumstances of the kind stated below;
- (a) war, hostilities (whether war be declared or not), invasion, act of foreign enemies;
 - (b) rebellion, terrorism, sabotage by persons other than the Contractor's personnel, revolution, insurrection, military or usurped power, or civil war ;
 - (c) riot, commotion, disorder, strike or lockout by persons other than the Contractor's personnel ;
 - (d) munitions of war, explosive materials, ionising radiation or contamination by radio-activity, except as may be attributable to the Contractor's use of such munitions, explosives, radiation or radio-activity ; and
 - (e) natural catastrophes such as fires, floods, epidemics, quarantine restrictions, freight embargoes, cyclone, hurricane, typhoon, tsunami, storm surge, earthquake, hill slides, landslides, and volcanic activities.

83.2 The Head of Procuring Entity decides the existence of a Force Majeure that will be the basis of the issuance of order for suspension of Works as stated under GCC Sub Clause 48.1.

84. Notice of Force Majeure

84.1 If a Party is or will be prevented from performing its substantial obligations under the Contract by Force Majeure, then it shall give notice, within fourteen (14) days after the party became aware, to the other Party of the event or circumstances constituting the Force Majeure and shall specify the obligations, the performance of which is or will be prevented.

84.2 Notwithstanding any other provision of this Clause, Force Majeure shall not apply to obligations of either Party to make payments to the other Party under the Contract.

85. Consequences of Force Majeure

85.1 The Contractor shall not be liable for forfeiture of its security, liquidated damages, or termination for default if and to the extent that it's delay in performance or other failure to perform its obligations under the Contract is the result of an event of Force Majeure.

85.2 the Contractor is prevented from performing its substantial obligations under the Contract by Force Majeure of which notice has been given under GCC Sub Clause 84, and suffers delay and/or incurs cost by reason of such Force Majeure, the Contractor shall be entitled subject to GCC Sub Clause 91 to:

- (a) an extension of time for any such delay, if completion is or will be delayed, under GCC Clause 44, and
- (b) if the event or circumstance is of the kind described sub-paragraphs (a) to (e) of GCC Sub Clause 83.1 occurs in the country, payment of any such cost, including the costs of rectifying or replacing the Works and physical services damaged or destructed by Force Majeure, to the extent they are not indemnified through the insurance policy referred to in GCC Clause 36.

85.3 After receiving notice under GCC Sub Clause 84.1, the Project Manager shall proceed to determine these matters under the provisions of the Contract.



86. Release from Performance

- 86.1 Notwithstanding any other provision of this Clause, if any event or circumstance outside the control of the parties (including, but not limited to, Force Majeure) arises which makes it impossible or unlawful for either or both Parties to fulfil its or their contractual obligations or which, under the law governing the Contract, entitles the Parties to be released from further performance of the Contract, then upon notice by either Party to the other party of such event or circumstance:
- (a) the Parties shall be discharged from further performance, without prejudice to the rights of either Party in respect of any previous breach of the Contract, and
 - (b) the sum payable by the Procuring Entity to the Contractor shall be the same as would have been payable under GCC Sub Clause 88.3 if the Contract had been terminated under GCC Sub Clause 87.3.

F. Termination

87. Termination

87.1 Termination for Default

- (a) The Procuring Entity or the Contractor, without prejudice to any other remedy for breach of Contract, by giving twenty-eight (28) days written notice of default to the other party, may terminate the Contract in whole or in part if the other party causes a fundamental breach of Contract. Fundamental breaches of the Contract shall include, but shall not be limited to, the following:
 - (i) the Contractor stops work for twenty-eight (28) days when no stoppage of work is shown on the current Programme and the stoppage has not been authorized by the Project Manager;
 - (ii) the Project Manager instructs the Contractor to delay the progress of the Works, and the instruction is not withdrawn within eighty four (84) days;
 - (iii) the Project Manager gives Notice that failure to correct a particular Defect is a fundamental breach of Contract and the Contractor fails to correct it within a reasonable period of time determined by the Project Manager;
 - (iv) the Contractor does not maintain a Security, which is required;
 - (v) the Contractor has delayed the completion of the Works by the number of days for which the maximum amount of Liquidated Damages can be paid, as specified in GCC Sub Clause 71;
 - (vi) the Contractor has subcontracted the whole of the Works or has assigned the Contract without the required agreement and without the approval of the Project Manager;
 - (vii) the Contractor, in the judgment of the Procuring Entity has engaged in corrupt or fraudulent practices, as defined in GCC Sub Clause 38, in competing for or in executing the Contract.
 - (viii) A payment certified by the Project Manager is not paid by the Procuring Entity to the Contractor within eighty-four (84) days of the date of the Project Manager's certificate.

87.2 Termination for Insolvency

The Procuring Entity and the Contractor may at any time terminate the Contract by giving twenty-eight (28) days written notice to the other party if either of the party becomes bankrupt or otherwise insolvent. In such event,



termination will be without compensation to any party, provided that such termination will not prejudice or affect any right of action or remedy that has accrued or will accrue thereafter to the other party.

87.3 Termination for Convenience

- (a) The Procuring Entity, by giving twenty-eight (28) days written notice sent to the Contractor, may terminate the Contract, in whole or in part, at any time for its convenience. The notice of termination shall specify that termination is for the Procuring Entity's convenience, the extent to which performance of the Contractor under the Contract is terminated, and the date upon which such termination becomes effective.
- (b) The Procuring Entity shall not terminate the contract under GCC Sub Clause 87.3(a) in order to execute the Works itself or to arrange for the Works to be executed by another contractor or to avoid a termination of the Contract by the Contractor as stated under GCC Sub Clause 87.1(a).

87.4 In the event the Procuring Entity terminates the Contract in whole or in part, the Procuring Entity shall accept the portion of the Works that are complete and ready for handing over after the Contractor's receipt of notice of termination of the Contract. For the remaining portion of the Works, the Procuring Entity may elect:

- (a) to have any portion completed by the Contractor at the Contract terms and prices; and/or
- (b) to cancel the remainder and pay to the Contractor an agreed amount for partially completed Works and for materials and parts previously procured by the Contractor, or
- (c) except in the case of termination for convenience as stated under GCC Sub Clause 87.3, engage another Contractor to complete the Works, and in that case the Contractor shall be liable to the Procuring Entity for any cost that may be incurred in excess of the sum that would have been paid to the Contractor, if the work would have been executed and completed by him or her.

87.5 If the Contract is terminated, the Contractor shall stop work immediately, make the Site safe and secure, and leave the Site as soon as is reasonably possible.

87.6 The expiration of the Intended Completion Date under GCC Clause 44 and, the initiation of settlement of disputes like amicable or adjudication and arbitration under GCC Clause 92 shall not be deemed a termination of the Contract under GCC Clause 87.

88. Payment upon Termination

88.1 If the Contract is terminated because of a fundamental breach of Contract under GCC Sub Clause 87.1 by the Contractor, the Project Manager shall issue a certificate for the value of the Works done and Plant and Materials ordered less advance payments received up to the date of the issue of the certificate and, further less the amount from percentage to apply to the contract value of the works not completed, as indicated in the PCC. If the total amount due to the Procuring Entity exceeds any payment due to the Contractor, the difference shall be a debt payable to the Procuring Entity.



- 88.2 If the Contract is terminated for the Procuring Entity's convenience or because of a fundamental breach of Contract by the Procuring Entity, the Project Manager shall issue a payment certificate for the value of the work done, Materials ordered, the reasonable cost of removal of Equipment, repatriation of the Contractor's foreign personnel employed solely on the Works and recruited specifically for the Works, and the Contractor's costs of protecting and securing the Works, and less advance payments received up to the date of the certificate.
- 88.3 If the Contract is terminated for reasons of Force Majeure, the Project Manager shall determine the value of the work done and issue a Payment Certificate which shall include:
- (a) the amounts payable for any work carried out for which unit rates or prices are stated in the Contract;
 - (b) the cost of Plant and Materials ordered for the Works which have been delivered to the Contractor, or of which the Contractor is liable to accept delivery: this Plant and Materials shall become the property of (and be at the risk of) the Procuring Entity when paid for by the Procuring Entity, and the Contractor shall place the same at the Procuring Entity's disposal;
 - (c) other costs or liabilities which in the circumstances were reasonably and necessarily incurred by the Contractor in the expectation of completing the Works;
 - (d) the cost of removal of Temporary Works and Contractor's Equipment from the Site; and
 - (e) the cost of repatriation of the Contractor's staff and labour employed wholly in connection with the Works at the date of termination.

89. Property

- 89.1 All Materials on the Site, Plant, Equipment, Temporary Works, and Works shall be deemed to be the property of the Procuring Entity if the Contract is terminated because of the Contractor's default stated under GCC Sub Clause 87.1.

90. Frustration

- 90.1 If the Contract is frustrated by the occurrence of a situation of Force Majeure as defined in GCC Sub Clause 83, the Project Manager shall certify that the Contract has been frustrated. The Contractor shall make the Site safe and stop work as quickly as possible after receiving this certificate and shall be paid for all works carried out before receiving it and for any work carried out afterwards to which a commitment was made.

G. Claims, Disputes and Settlement

91. Contractor's Claims

- 91.1 If the Contractor considers himself to be entitled to any extension of the Completion Time and/or any additional payment, under any Clause of these Conditions or otherwise in connection with the Contract, the Contractor shall give notice to the Procuring Entity, describing the event or circumstance giving rise to the claim. The notice shall be given as soon as practicable, and not later than twenty-eight (28) days after the Contractor became aware, or should have become aware, of the event or circumstance.
- 91.2 If the Contractor fails to give notice of a claim within such period of twenty-eight (28) days, the Intended Completion Date shall not be extended, the Contractor shall not be entitled to additional payment, and the Procuring Entity shall be discharged from all liability in connection with the claim.



91.3 Within forty two (42) days after the Contractor became aware or should have become aware of the event or circumstance giving rise to the claim, or within such other period as may be proposed by the Contractor and approved by the Project Manager, the Contractor shall send to the Project Manager a fully detailed claim which includes full supporting particulars of the basis of the claim and of the extension of time and/or additional payment claimed, for settlement.

92. Settlement of Disputes

92.1 Amicable settlement

The procuring Entity and the Contractor shall use their best efforts to settle amicably all possible disputes arising out of or in connection with this Contract or its interpretation.

92.2 Adjudication

- (a) If the Contractor believes that a decision taken by the Project Manager was either outside the authority given to the Project Manager by the Contract or that the decision was wrongly taken, the decision shall be referred to the Adjudicator within fourteen (14) days of notification of the Project Manager's decision in writing.
- (b) The Adjudicator named in the **PCC** is jointly appointed by the parties. In case of disagreement between the parties, the Appointing Authority designated in the **PCC** shall appoint the Adjudicator within fourteen (14) days of receipt of a request from either party.
- (c) The Adjudicator shall give its decision in writing to both parties within twenty-eight (28) days of a dispute being referred to it.
- (d) The Contractor shall make all payments (fees and reimbursable expenses) to the Adjudicator, and the Procuring Entity shall reimburse half of these fees through the regular progress payments.
- (e) Should the Adjudicator resign or die, or should the Procuring Entity and the Contractor agree that the Adjudicator is not functioning in accordance with the provisions of the Contract; a new Adjudicator will be jointly appointed by the Procuring Entity and the Contractor. In case of disagreement between the Procuring Entity and the Contractor the Adjudicator shall be designated by the Appointing Authority within fourteen (14) days of receipt of a request from either party as stated under GCC Sub Clause 92.2 (b).

92.3 Arbitration

- (a) If the parties are unable to reach a settlement as per GCC Clauses 92.1 and 92.2 within twenty-eight (28) days of the first written correspondence on the matter of disagreement, then either party may give notice to the other party of its intention to commence arbitration in accordance with GCC Sub Clause 94.3(b).
- (b) The arbitration shall be conducted in accordance with the Arbitration Act (**Act No 1 of 2001**) of Bangladesh as at present in force and in the place shown in the **PCC**.

Section 4. Particular Conditions of Contract



GCC Clause	Amendments of, and Supplements to, Clauses in the General Conditions of Contract
GCC 1.1(k)	The Contractor is: [Name, address, and name of authorized representative]
GCC 1.1(z)	The Intended Completion Date for the Works shall be: 270 (Two hundred and seventy) days from the date of getting hot work permit or electrical connection.
GCC 1.1(cc)	The original Contract Price is [as per NOA]
GCC 1.1(gg)	The Procuring Entity is: Bangladesh Petroleum Corporation (BPC) , Executing agency: Eastern Refinery Limited (ERL) .
GCC 1.1(hh)	The Project Manager is: Mamshad Karim Anwar, Assistant General Manager (Development), Eastern Refinery Limited.
GCC 1.1(ll)	The site(s) is located at Eastern Refinery Limited Tank Farm Area and is defined in the drawing no.: ER/DEV (M)-40(1)/2022-1.
GCC 1.1(oo)	The Start Date shall be: within 7 (seven) days after receiving hot work execution permit from Safety department & getting electrical connection.
GCC 1.1(ss)	The Works consist of renovation of 1 (one) Crude Oil Storage Tank having capacity of 32,000 cubic meter including cleaning, earth work, repair/replacement of bottom, roof, roof railing, wind girder, leg & leg casing, stairway, pipelines, tank mat, pad etc. and sandblasting, painting including attachments as required.
GCC 2.5	The Sectional Completion Dates are: Not Applicable .
GCC 3.1	<p>The Procuring Entity's address for the purpose of communications under this contract is :</p> <p>Contact person: Mamshad Karim Anwar, Assistant General Manager (Development)</p> <p>Address: Eastern Refinery Limited, North Patenga, Chattogram-4204, Bangladesh.</p> <p>Telephone: 02333301261-7, Ext: 460</p> <p>Fax No.: 8802333301269.</p> <p>E-mail address: agmdevelopment@erl.com.bd; md-office@erl.com.bd.</p> <p>The Contractor's address for the purpose of communications under this contract is :</p> <p>Contact person:</p> <p>Address:</p> <p>Tel:</p> <p>Fax:</p> <p>E-mail address:</p>
GCC 6.1(j)	Other documents forming part of the Contract are; <ul style="list-style-type: none"> a) Schedule of key personnel; b) Relevant correspondence prior to signing of the contract; c) List of machineries and other attachments as mentioned in ITT 17.1. d) Any other information the Tenderer feels necessary to include.

GCC 9.1	The Contractor or the Subcontractor that is a national of, or registered in, the following countries are not eligible: Those countries with which Bangladesh has no diplomatic relationship.															
GCC 9.2	Materials, Equipment, Plants, and Supplies shall not have their origin in the following countries: Those countries with which Bangladesh has no diplomatic relationship.															
GCC 13.1	Possession of the Site or part(s) of the Site, to the Contractor shall be given: Immediately after getting work permit from Safety Department.															
GCC 19.1	<p>Following Key Personnel to carry out the functions stated in the Schedule shall be employed by the Contractor:</p> <table border="1" data-bbox="432 524 1382 808"> <thead> <tr> <th data-bbox="432 524 746 613">No</th> <th data-bbox="746 524 1062 613">Name of key Personnel</th> <th data-bbox="1062 524 1382 613">Position</th> </tr> </thead> <tbody> <tr> <td> </td> <td> </td> <td> </td> </tr> <tr> <td> </td> <td> </td> <td> </td> </tr> <tr> <td> </td> <td> </td> <td> </td> </tr> <tr> <td> </td> <td> </td> <td> </td> </tr> </tbody> </table>	No	Name of key Personnel	Position												
No	Name of key Personnel	Position														
GCC 20.3	Nominated Subcontractor(s): Not Applicable.															
GCC 22.1	The Contractual matters between the Procuring Entity and the Contractor shall be decided by: Not Applicable.															
GCC 36.1	<p>The insurance cover shall be:</p> <table border="1" data-bbox="424 999 1449 1821"> <tbody> <tr> <td data-bbox="424 999 491 1160">(a)</td> <td data-bbox="491 999 1449 1160">The minimum cover for the Works and of Plant and Materials is Tk. <i>[state amount]</i>. <i>[the Procuring Entity shall state the amount at the time of preparing PCC. Amount could be 110% of the value of the works, plant and materials]</i></td> </tr> <tr> <td data-bbox="424 1160 491 1317">(b)</td> <td data-bbox="491 1160 1449 1317">The maximum deductible for insurance of the Works and of Plant and Materials is <i>[state amount]</i>. <i>[the Contractor shall state this amount at the time of Contract signing. Amount could be 5 to 10 % of the sum insured]</i></td> </tr> <tr> <td data-bbox="424 1317 491 1447">(c)</td> <td data-bbox="491 1317 1449 1447">The minimum cover for loss or damage to Equipment is Tk. <i>[state amount]</i>. <i>[the Procuring Entity shall state the amount at the time of preparing PCC. Amount could be 110% of the replacement value of the equipment]</i></td> </tr> <tr> <td data-bbox="424 1447 491 1576">(d)</td> <td data-bbox="491 1447 1449 1576">The maximum deductible for insurance of Equipment is <i>[state amount]</i>. <i>[the Contractor shall state this amount at the time of Contract signing. Amount could be 5 to 10 % of the sum insured]</i>.</td> </tr> <tr> <td data-bbox="424 1576 491 1706">(e)</td> <td data-bbox="491 1576 1449 1706">The minimum cover for other property is <i>[state amount]</i>. <i>[the Procuring Entity shall state the amount at the time of preparing PCC. Amount could be 10% of the Contract Price]</i></td> </tr> <tr> <td data-bbox="424 1706 491 1821">(f)</td> <td data-bbox="491 1706 1449 1821">The maximum deductible for insurance of other property is <i>[state amount]</i>. <i>[the Contractor shall state this amount at the time of Contract signing. Amount could be 5 to 10% of sum insured]</i></td> </tr> </tbody> </table>	(a)	The minimum cover for the Works and of Plant and Materials is Tk. <i>[state amount]</i> . <i>[the Procuring Entity shall state the amount at the time of preparing PCC. Amount could be 110% of the value of the works, plant and materials]</i>	(b)	The maximum deductible for insurance of the Works and of Plant and Materials is <i>[state amount]</i> . <i>[the Contractor shall state this amount at the time of Contract signing. Amount could be 5 to 10 % of the sum insured]</i>	(c)	The minimum cover for loss or damage to Equipment is Tk. <i>[state amount]</i> . <i>[the Procuring Entity shall state the amount at the time of preparing PCC. Amount could be 110% of the replacement value of the equipment]</i>	(d)	The maximum deductible for insurance of Equipment is <i>[state amount]</i> . <i>[the Contractor shall state this amount at the time of Contract signing. Amount could be 5 to 10 % of the sum insured]</i> .	(e)	The minimum cover for other property is <i>[state amount]</i> . <i>[the Procuring Entity shall state the amount at the time of preparing PCC. Amount could be 10% of the Contract Price]</i>	(f)	The maximum deductible for insurance of other property is <i>[state amount]</i> . <i>[the Contractor shall state this amount at the time of Contract signing. Amount could be 5 to 10% of sum insured]</i>			
(a)	The minimum cover for the Works and of Plant and Materials is Tk. <i>[state amount]</i> . <i>[the Procuring Entity shall state the amount at the time of preparing PCC. Amount could be 110% of the value of the works, plant and materials]</i>															
(b)	The maximum deductible for insurance of the Works and of Plant and Materials is <i>[state amount]</i> . <i>[the Contractor shall state this amount at the time of Contract signing. Amount could be 5 to 10 % of the sum insured]</i>															
(c)	The minimum cover for loss or damage to Equipment is Tk. <i>[state amount]</i> . <i>[the Procuring Entity shall state the amount at the time of preparing PCC. Amount could be 110% of the replacement value of the equipment]</i>															
(d)	The maximum deductible for insurance of Equipment is <i>[state amount]</i> . <i>[the Contractor shall state this amount at the time of Contract signing. Amount could be 5 to 10 % of the sum insured]</i> .															
(e)	The minimum cover for other property is <i>[state amount]</i> . <i>[the Procuring Entity shall state the amount at the time of preparing PCC. Amount could be 10% of the Contract Price]</i>															
(f)	The maximum deductible for insurance of other property is <i>[state amount]</i> . <i>[the Contractor shall state this amount at the time of Contract signing. Amount could be 5 to 10% of sum insured]</i>															



	(g) The minimum cover for personal injury or death: (i) for the Contractor's employees is as per the law and common practice in Bangladesh. (ii) and for third parties is as per the law and common practice in Bangladesh.
GCC 39.1	Commencement Date shall be: Within 7 (seven) days after receiving hot work execution permit from Safety department & getting electrical connection.
GCC 40.1	The Intended Completion Date of the Works shall be: 270 (Two hundred and seventy) days from the commencement date.
GCC 41.1	The Contractor shall submit a Programme for the Works within 15 (fifteen) days of signing the Contract.
GCC 41.2	The period between Programme updates is quarterly .
GCC 41.3	The amount to be withheld for late submission of an updated Programme is 10,000.00 (Ten thousand) .
GCC 56.1	The Defects Liability Period is 12 (Twelve) months .
GCC 64.3	Each Running Bill shall be minimum 25% (Twenty five percent) of the total contract value.
GCC 65.3	The particulars of the Bank Account nominated are as follows : Title of the Account : [insert title to whom the Contract awarded] Name of the Bank : [insert name with code, if any] Name of the Branch : [insert branch name with code ,if any] Account Number : [insert number] Address : [insert location with district] Tel : Fax : e-mail address : <i>[information furnished by the Contractor shall be substantiated by the concerned Bank and authenticated by the Procuring Entity]</i>
GCC 66.1	The rate of interest shall be the prevailing rate of interest for commercial borrowing established in the country: None .
GCC 67.1(k)	The following additional events shall also be the Compensation Events : unavoidable circumstances, such as, pandemic situation, Hartal, Earth Quake, Rain, Storm, electricity disruption, various reasons considering the safe operation of the Process Plant, Installation of ERL or any other unavoidable circumstances which are beyond the control.
GCC 69.1	The Contract is not subject to price adjustment.
GCC 70.1	The proportion of payments to be retained is: None .
GCC 71.1	The amount of Liquidated Damages is 0.05 of 1 (One) percent of the contract value of the uncompleted works or any part thereof completed after expiry of the Intended Completion Date or extended Intended Completion Date, as applicable, per day of delay. The maximum amount of Liquidated Damages for the uncompleted Works or any part thereof is 05 (Five) percent of the final Contract Price of the whole of the Works.



GCC 72.1	The Bonus for the whole of the Works is: Not Applicable.
	The maximum amount of Bonus for the whole of the Works: Not Applicable.
GCC 73.1	The Advance Payment shall be: Not Applicable.
GCC 73.4	Advance Payment shall be amortized at the rate of from the progressive payments of invoices: Not Applicable.
GCC 75.2	The percentage for adjustment of Provisional Sums is: Not Applicable.
GCC 82.1	The date by which “as-built” drawings are required is: Not Applicable.
GCC 82.2	The amount to be withheld for failing to produce “as-built” drawings and/or operating and maintenance manuals by the date required is: Not Applicable.
GCC 88.1	The percentage to apply to the contract value of the works not completed, representing the Procuring Entity’s additional cost for completing the uncompleted Works, is 10 (Ten) percent.
GCC 92.2(b)	The Adjudicator jointly appointed by the parties is: BPC/ERL.
	In case of disagreement between the parties, the Appointing Authority for the Adjudicator is the President of the Institution of Engineers, Bangladesh (IEB).
GCC 92.3(b)	The arbitration shall be conducted in the place mentioned below: Bureau of Research, Testing and Consultancy (BRTC), Bangladesh University of Engineering and Technology (BUET) Dhaka, Bangladesh.

Additional Conditions of Contract



Clause No.	These conditions must be followed
01	Tenderers should visit the job site and should read the plan of tank, also the detailed specification available with ERL Development Department in their own interest before submission of tender. No claim will be entertained for lack of knowledge.
02	The contractor shall be responsible for proper and safe storing of materials of his own and that of ERL right after issue from ERL store. In this respect ERL will not entertain any demand or claim for any damage or loss of materials under any circumstances.
03	In case of unavoidable Circumstances if the offer cannot be received or opened on the specified date, it will be received/opened on the following working day.
04	For unforeseen items mutually negotiated rates will be accepted considering the market value at that time.
05	Tenderers must write clearly their full address including the phone number, cell number to the left hand side on the envelope.
06	ERL reserves the right to add or to cancel/delete/vary one or more than one items or quantity without any compensation and engage other contractors simultaneously for any item or for the whole job in the interest of the quality and quick progress of the work or to complete the job within the fixed period.
07	ERL may issue a variation order in case of inclusion or reduction in working volume. Tenderer(s) will not be entitled to claim against the variation order. ERL will have the authority to change the completion date proportionate to inclusion or reduction of volume of work.
08	The subject work is to be executed in the hazardous zone of the restricted area of ERL. So the contractor must follow the safety and security rules of ERL strictly, failing which action will be taken as per safety and security rule of ERL. The contractor must equip his people with safety gears for ensuring personal safety. Information regarding safety and security rules is available with Development department.
09	All working people under the employment of contractor during the tenure of this contract should always be under their close supervision. In no way their working people should loiter any where inside ERL. At the closing of day work or at any break all working people should be sent out side under the contractor's supervision having clearance/checking by ERL Security personnel.
10	The contractor shall have to take full responsibility of his workers (who will work under this contract) regarding any subversive activities within ERL. ERL's decision will be treated as final in this respect.
11	It will be the bonded responsibility of the contractor to remove instantly from the work site any worker if found guilty in connection with clause No. 09 & 10 of this contract or unsuitable, negligence to duty by the concerned authority of ERL. Contractor will be bound to bring replacement within reasonable time as decided by the ERL authority. The contractor will also fulfill any loss if caused due to subversive activity by himself or by his people who will be engaged in the job under this contract.



12	It is to be clearly understood by the contractor that all works under execution shall for all times be kept open for inspection and supervision by any authorized officer of ERL. The contractor will furnish instantly the information about job done under this contract. The contractor himself or any of his authorized representative will always be present at the job site for receiving instructions or recording the measurement of work, he will also maintain day to day job progress report which should be signed by the concerned authority of ERL.
13	The contractor shall be fully responsible for any kind of accident fatal or non-fatal, major or minor injury while executing the work to himself, his staff or any other person. In all such cases, compensation as per rules payable to the claimant will be paid by the contractor. The responsibility for the loss of any property whether to ERL or to any third person shall also lie with the contractor. The contractor shall be responsible to make good such damages as directed by ERL or by any court. In all such cases the contractor will keep ERL absolutely indemnified and free from any responsibility.
14	The contractor shall have to engage trained and experienced Project/Site in-charge, supervisor, fitter/fabricators, welders preferably petroleum grade welders. The Bio-data/Experience Certificate of such workers should be attached with the tender. Their acceptability subject to practical test at ERL and should be certified by the concerned authority of ERL.
15	Fitters & welders of the contractor have to face quantitative and qualitative practical test at site or ERL workshop. They should be able to work at any height and position of tank. Only test passed persons shall be allowed to work in the tank.
16	Quality of work shall be of the first order. For improper or irregular or haphazard work done the contractor will have to rectify the defects. No compensation will be entertained for such rectification work
17	A written intimation from Manager (Inspection) will be forth coming for improper and haphazard work done. If corrective action is not taken by the contractor (within three days) after receiving such written instruction will be considered as a breach of contract.
18	Electrode should be baked (if necessary) for 2 hours before use at 300°C and oven needed for baking is to be arranged by the contractor.
19	Tri-joints in the roof & bottom plates should be properly forced into sealing lap by heating and hammering the plates as required.
20	For repair shell, roof, roof railing, wind girder etc. of the tank, contractor will make necessary arrangement for lifting, positioning the plates at different required heights of the tank. Any moveable platform needed to carry out the job to be arranged by the contractor including its movement as and when required.
21	After completion of the work welding spots on the tank are to be removed/rectified by grinding flush and welding as per instruction/direction of the ERL authority.



Appendix to the Tender

[In Tables below, the Procuring Entity shall indicate the source and base values with dates of Indexes, unless otherwise instructed to be quoted by the Tenderers, for the different Cost Components and mention its Weightings or Coefficients]

Table 1.1: Price Adjustment Data
[ITT Sub Clause 27.8: To be provided by the Procuring Entity]

Index Descriptions	Base Value	Sources of Index

Note:

1. The sources of Indexes and its values with dates shall be Bangladesh Bureau of Statistics (BBS) unless otherwise mentioned by the Procuring Entity.
2. The Base Value of the Indexes shall be those prevailing twenty-eight (28) days prior to the deadline for submission of the Tenders.



**Table 1.2: Price Adjustment Data
[GCC Clause 69: To be provided by the Procuring Entity]**

Item Group	Bill No. if applicable	Index Descriptions	Coefficients or Weightings for non-adjustable Cost Component	Coefficients or Weightings for adjustable Cost Components										Total	
				a	b	c	d	e	f	g	h	i	j		
															1
															1
															1
															1
															1
															1

Note:

The Weightings or Coefficients of the Cost Components shall be mentioned by the Procuring Entity based on the proportion of components involved in the work items caused to be impacted by rise and fall in its prices.



Section 5. Tender and Contract Forms

Form	Title
Tender Forms	
PW3A – 1a	Technical offer Submission Letter
PW3A – 1b	Financial offer Submission Letter
PW3A – 2	Tenderer Information
PW3A – 3	JV Partner Information (<i>if applicable</i>)
PW3A – 4	Subcontractor Information (<i>if applicable</i>)
PW3A – 5	Personnel Information
PW3A – 6	Bank Guarantee for Tender Security (<i>when this option is chosen</i>)
PW3A - 7	Bank's Letter of Commitment for Line of Credit (<i>when this option is chosen</i>)
Contract Forms	
PW3A – 8	Notification of Award
PW3A – 9	Contract Agreement
PW3A – 10	Bank Guarantee for Performance Security (<i>when this option is chosen</i>)
PW3A –11	Bank Guarantee for Advance Payment (<i>if applicable</i>)
PW3A –12	Bank Guarantee for Retention Money Security (<i>when this option is chosen</i>)

Forms **PW3A-1** to **PW3A -7** comprises part of the Tender Format and should be completed as stated in ITT Clauses 24.

Forms **PW3A-8** to **PW3A -12** comprises part of the Contract as stated in GCC Clause 6.

Technical Offer Submission Letter (Form PW3A-1a)



*[This letter should be completed and signed by the Authorised Signatory
on the Letter-Head Pad of the Tenderer]*

To: <i>[Contact Person]</i> <i>[Name of the Procuring Entity]</i> <i>[Address of the Procuring Entity]</i>	Date:
Invitation for Tender No:	
Tender Package No:	
Lot No: <i>(when applicable)</i>	

We, the undersigned, tender to execute in conformity with the Tender Document, the following Works and physical services, viz.:

In signing this letter, and in submitting our Tender, we also confirm that:

- a) our Tender shall be valid for the period stated in the Tender Data Sheet (ITT Sub Clause 33.1) and it shall remain binding upon us and may be accepted at any time before the expiration of that period;
- b) a Tender Security is attached in the form of a *[state Pay Order, Bank Draft, Bank Guarantee]* in the amount stated in the Tender Data Sheet (ITT Sub Clause 36.1) and valid for a period of twenty-eight (28) days beyond the Tender Validity date;
- c) if our Tender is accepted, we commit to furnishing a Performance Security within the time stated under ITT Sub Clause 69.2 in the amount stated in the Tender Data Sheet (ITT Sub Clauses 68.1) and in the form specified in the Tender Data Sheet (ITT Sub Clause 69.1) valid for a period of twenty-eight (28) days beyond the date of issue of the Completion Certificate of the Works;
- d) we have examined and have no reservations to the Tender Document, issued by you on *[insert date]*; including Addendum to Tender Document No(s) *[state numbers]*, issued in accordance with the Instructions to Tenderers (ITT Clause 11). *[insert the number and issuing date of each addendum; or delete this sentence if no Addendum has been issued]*;
- e) we, including as applicable, any JV partner or Subcontractor for any part of the contract resulting from this Tender process, have nationalities from eligible countries, in accordance with ITT Sub Clause 5.1;
- f) we are submitting this Tender as a sole Tenderer in accordance with ITT Sub Clause 40.4
or
 we are submitting this Tender as the partners of a JV, comprising the following other partners in accordance with ITT Sub Clause 40.4;

	Name of Partner	Location & District of Partner
1		

2		
3		
4		



- g) we are not a Government owned entity as defined in ITT Sub Clause 5.3
or
we are a Government owned entity, and we meet the requirements of ITT Sub Clause 5.10;
- h) we, including as applicable any JV partner, declare that we are not associated, nor have been associated in the past, directly or indirectly, with a consultant or any other entity that has prepared the design, specifications and other documents in accordance with ITT Sub Clause 5.6;
- i) we, including as applicable any JV partner or Subcontractor for any part of the contract resulting from this Tender process, have not been declared ineligible by the Government of Bangladesh on charges of engaging in corrupt, fraudulent, collusive or coercive practices in accordance with ITT Sub Clause 5.7;
- j) furthermore, we are aware of ITT Clause 4 concerning such practices and pledge not to indulge in such practices in competing for or in executing the Contract;
- k) we intend to subcontract an activity or part of the Works, in accordance with ITT Sub Clause 19.1, to the following Subcontractor(s);

Activity or part of the Works	Name of Subcontractor with Location and District

- l) we, including as applicable any JV partner, confirm that we do not have a record of poor performance, such as abandoning the works, not properly completing contracts, inordinate delays, or financial failure as stated in ITT Clause 5.8, and that we do not have, or have had, any litigation against us, other than that stated in the Tenderer Information (**Form PW3A-2**);
- m) we are not participating as Tenderer in more than one Tender in this Tendering process. We understand that your written Notification of Award shall constitute the acceptance of our Tender and shall become a binding Contract between us, until a formal Contract is prepared and executed;
- n) we, including as applicable any JV partner, confirm that we do not have a record of insolvency, receivership, bankrupt or being wound up, our business activities were not been suspended, and it was not been the subject of legal proceedings in accordance with ITT Sub Clause 5.9;
- o) we, including as applicable any JV partner, confirm that we have fulfilled our obligations to pay taxes and social security contributions applicable under the relevant national laws and regulations of Bangladesh in accordance with ITT Sub Clause 5.5;
- p) we understand that you reserve the right to reject all the Tenders or annul the Tender proceedings, without incurring any liability to Tenderer, in accordance with ITT Clause 63.



Signature:	<i>[insert signature of authorised representative of the Tenderer]</i>
Name:	<i>[insert full name of signatory with National ID Number]</i>
In the capacity of:	<i>[insert capacity of signatory]</i>
Duly authorised to sign the Tender for and on behalf of the Tenderer	

[If there is more than one (1) signatory, or in the case of a JV, add other boxes and sign accordingly].

Attachment 1:

[ITT Sub Clause 40.4]

Written confirmation authorising the above signatory(ies) to commit the Tenderer.

[and, if applicable]

Attachment 2:

[ITT Sub Clause 29.2(b)]

Copy of the JV Agreement/Letter of Intent to form JV with draft proposed Agreement.

Financial Offer Submission Letter (Form PW3A-1b)



*[This letter should be completed and signed by the Authorized Signatory
on the Letter-Head Pad of the Tenderer]*

To: <i>[Contact Person]</i> <i>[Name of the Procuring Entity]</i> <i>[Address of the Procuring Entity]</i>	Date:
Invitation for Tender No:	IFT No. _____
Tender Package No:	Package No. _____
Lot No: <i>(when applicable)</i>	Lot No. _____

We, the undersigned, tender to execute in conformity with the Tender Document, the following Works and physical services, viz.:

In accordance with ITT Clause 27 and 28, the following price applies to our Tender:

The Tender price is: (ITT Sub Clause 27.4 and 28.1)	Tk. _____ <i>[in figures]</i> Taka _____ <i>[in words]</i>
In accordance with ITT Clause 27.6, the following discounts shall apply to our Tender:	
The unconditional discount proposed in this package/Lot is:	In Percentage (%) -----

The discount shall be equally applicable on all the items of BOQ after arithmetical correction.

In signing this letter, and in submitting our Tender, we also confirm that:

- (a) our Tender shall be valid for the period stated in the Tender Data Sheet (ITT Sub Clause 33.1) and it shall remain binding upon us and may be accepted at any time before the expiration of that period;
- (b) a Tender Security is attached in the form of a *[state Pay Order, Bank Draft, Bank Guarantee]* in the amount stated in the Tender Data Sheet (ITT Sub Clause 36.1) and valid for a period of twenty-eight (28) days beyond the Tender Validity date;
- (c) if our Tender is accepted, we commit to furnishing a Performance Security within the time stated under ITT Sub Clause 69.2 in the amount stated in the Tender Data Sheet (ITT Sub Clauses 68.1) and in the form specified in the Tender Data Sheet (ITT Sub Clause 66.1) valid for a period of twenty-eight (28) days beyond the date of issue of the Completion Certificate of the Works;



- (d) we have examined and have no reservations to the Tender Document, issued by you on *[insert date]*; including Addendum to Tender Document No(s) *[state numbers]*, issued in accordance with the Instructions to Tenderers (ITT Clause 11). *[insert the number and issuing date of each addendum; or delete this sentence if no Addendum has been issued]*;
- (e) we, including as applicable, any JV partner or Subcontractor for any part of the contract resulting from this Tender process, have nationalities from eligible countries, in accordance with ITT Sub Clause 5.1;
- (f) we are submitting this Tender as a sole Tenderer in accordance with ITT Sub Clause 40.4
or
we are submitting this Tender as the partners of a JV, comprising the following other partners in accordance with ITT Sub Clause 40.4;

	Name of Partner	Location & District of Partner
1		
2		
3		
4		

- (g) we are not a Government owned entity as defined in ITT Sub Clause 5.3
or
we are a Government owned entity, and we meet the requirements of ITT Sub Clause 5.10;
- (h) we, including as applicable any JV partner, declare that we are not associated, nor have been associated in the past, directly or indirectly, with a consultant or any other entity that has prepared the design, specifications and other documents in accordance with ITT Sub Clause 5.6;
- (i) we, including as applicable any JV partner or Subcontractor for any part of the contract resulting from this Tender process, have not been declared ineligible by the Government of Bangladesh on charges of engaging in corrupt, fraudulent, collusive or coercive practices in accordance with ITT Sub Clause 5.7;
- (j) furthermore, we are aware of ITT Clause 4 concerning such practices and pledge not to indulge in such practices in competing for or in executing the Contract;
- (k) we intend to subcontract an activity or part of the Works, in accordance with ITT Sub Clause 19.1, to the following Subcontractor(s);

Activity or part of the Works	Name of Subcontractor with Location and District

- (l) we, including as applicable any JV partner, confirm that we do not have a record of poor performance, such as abandoning the works, not properly completing contracts, inordinate delays, or financial failure as stated in ITT Clause 5.8, and that we do not have, or have had, any litigation against us, other than that stated in the Tenderer Information (**Form PW3A-2**);



- (m) we are not participating as Tenderer in more than one Tender in this Tendering process. We understand that your written Notification of Award shall constitute the acceptance of our Tender and shall become a binding Contract between us, until a formal Contract is prepared and executed;
- (n) we, including as applicable any JV partner, confirm that we do not have a record of insolvency, receivership, bankrupt or being wound up, our business activities were not been suspended, and it was not been the subject of legal proceedings in accordance with ITT Sub Clause 5.9;
- (o) we, including as applicable any JV partner, confirm that we have fulfilled our obligations to pay taxes and social security contributions applicable under the relevant national laws and regulations of Bangladesh in accordance with ITT Sub Clause 5.5;
- (p) we understand that you reserve the right to reject all the Tenders or annul the Tender proceedings, without incurring any liability to Tenderer, in accordance with ITT Clause 63.

Signature:	<i>[insert signature of authorised representative of the Tenderer]</i>
Name:	<i>[insert full name of signatory with National ID Number]</i>
In the capacity of:	<i>[insert capacity of signatory]</i>
Duly authorised to sign the Tender for and on behalf of the Tenderer	

[If there is more than one (1) signatory, or in the case of a JV, add other boxes and sign accordingly].

Attachment 1:

[ITT Sub Clause 40.4]

Written confirmation authorising the above signatory(ies) to commit the Tenderer.

[and, if applicable]

Attachment 2:

[ITT Sub Clause 29.2(b)]

Copy of the JV Agreement/Letter of Intent to form JV with draft proposed Agreement.

Tenderer Information (Form PW3A-2)



[This Form should be completed only by the Tenderer, preferably on its Letter-Head Pad]

Invitation for Tender No:

[IFT No]

Tender Package No:

[Package No]

Lot No (*when applicable*)

[Lot No]

1.	Eligibility Information of the Tenderer [ITT Clauses 5 & 29]		
1.1	Nationality of individual or country of registration		
1.2	Tenderer's legal title		
1.3	Tenderer's registered address		
1.4	Tenderer's legal status <i>[complete the relevant box]</i>		
	Proprietorship		
	Partnership		
	Limited Liability Concern		
	Government-owned Enterprise		
	Others <i>[please describe, if applicable]</i>		
1.5	Tenderer's year of registration		
1.6	Tenderer's authorised representative details		
	Name		
	National ID number		
	Address		
	Telephone / Fax numbers		
	e-mail address		
1.7	Litigation [ITT Cause 13]		
	A. No pending litigation		<input type="checkbox"/> <i>[if no pending litigation put Tick Mark in Box]</i>
	B. Pending litigation		
	Year	Matter in dispute	Value of Pending Claim in Taka
			Value of Pending Claim as Percentage of Net Worth
1.8	Tenderer to attach photocopies of the original documents mentioned aside	[All documents required under ITT Clauses 5 and 29]	



The following two information are applicable for National Tenderers				
1.9	Tenderer's Value Added Tax Registration (VAT) Number			
1.10	Tenderer's Tax Identification Number (TIN)			
[The foreign Tenderers, in accordance with ITT Sub Clause 5.1, shall provide evidence by a written declaration to that effect to demonstrate that it meets the criterion]				
2. Qualification Information of the Tenderer [ITT Clause 32]				
2.1	General Experience in Construction Works of Tenderer [State years of experience]			
2.2	Specific Experience in Construction Works of Tenderer Completed Contracts of similar nature, complexity and methods/construction technology			
	Contract No	[insert reference no] of [insert year]		
	Name of Contract	[insert name]		
	Role in Contract <i>[tick relevant box].</i>	Prime Contractor	Subcontractor	Management Contractor
	Award date	[insert date]		
	Completion date	[insert date]		
Total Contract Value	[insert amount]			
Procurring Entity's Name Address Tel / Fax <u>e-mail</u> Brief description with justifications of the similarity compared to the Procurring Entity's requirements	[state justification in support of its similarity compared to the proposed works]			
2.3	Average annual construction turnover [ITT Sub Clause 15.1(a)] <i>[total certified payments received for contracts in progress or completed under public sector for a period as stated under ITT Sub Clause 15.1(a), using rate of exchange at the end of the period reported]</i>			
	Year	Currency	Amount Taka or Equivalent Taka	



2.4	Liquid assets available to meet the construction cash flow [ITT Sub Clause 15.1(b)]			
	No	Source of Financing	Amount Available	
In order to confirm the above statements the Tenderer shall submit , as applicable, the documents mentioned in ITT Sub Clause 32.1(d)				
2.5	Contact Details [ITT Sub Clause 32.1 (h)]			
	Name, address, and other contact details of Tenderer Bankers and other Procuring Entity(s) that may provide references, if contacted by this Procuring Entity			
2.6	Qualifications and experience of key technical and administrative personnel proposed for Contract administration and management [ITT Sub Clause 32.1(f)]			
	Name	Position	Years of General Experience	Years of Specific Experience
<i>[Tenderer to complete details of as many personnel as are applicable. Each personnel listed above should complete the Personnel Information (Form PW3A-5)]</i>				
2.7	Major Construction Equipment proposed to carry out the Contract [ITT Sub Clause 32.1(g)]			
	Item of Equipment	Condition (new, good, average, poor)	Owned, leased or to be purchased (state owner, lessor or seller)	
<i>[Tenderer to list details of each item of major construction equipment, as applicable]</i>				

JV Partner Information (Form PW3A-3)



[This Form should be completed by each JV partner].

Invitation for Tender No: [IFT No]
 Tender Package No: [Package No]
 Lot No. (when applicable) [Lot No]

1. Eligibility Information of the JV Partner [ITT Clauses 5 & 29]			
1.1	Nationality of individual or country of registration		
1.2	JV Partner's legal title		
1.3	JV Partner's registered address		
1.4	JV Partner's legal status <i>[complete the relevant box]</i>		
	Proprietorship		
	Partnership		
	Limited Liability Concern		
	Government-owned Enterprise		
	Others <i>[please describe, if applicable]</i>		
1.5	JV Partner's year of registration		
1.6	JV Partner's authorised representative details		
	Name		
	National ID number		
	Address		
	Telephone / Fax numbers		
	e-mail address		
1.7	Litigation [ITT Cause 13]		
	A. No pending litigation <input type="checkbox"/> <i>[if no pending litigation put Tick Mark in Box]</i>		
	B. Pending litigation		
	Year	Matter in dispute	Value of Pending Claim in Taka
			Value of Pending Claim as Percentage of Net Worth



1.8	JV Partner to attach photocopies of the original documents mentioned aside	[All documents required under ITT Clauses 5 and 29]		
The following two information are applicable for national JV Partners only				
1.9	JV Partner's Value Added Tax Registration (VAT) Number			
1.10	JV Partner's Tax Identification Number(TIN)			
[The foreign JV Partners, in accordance with ITT Sub Clause 5.1, shall provide evidence by a written declaration to that effect to demonstrate that it meets the criterion]				
2.	Key Activity(ies) for which it is intended to be joint ventured, if it can be specified [ITT Sub Clause 18.2]			
	Elements of Activity	Brief description of Activity		
3.	Qualification Information of the JV Partners[ITT Clause 32]			
3.1	General Experience in Construction Works of JV Partners[State years of experience]			
3.2	Specific Experience in Construction Works of JV Partners Completed Contracts of similar nature, complexity and methods/construction technology			
	Contract No	[insert reference no] of [insert year]		
	Name of Contract	[insert name]		
	Role in Contract <i>[tick relevant box].</i>	Prime Contractor	Subcontractor	Management Contractor
	Award date	[insert date]		
	Completion date	[insert date]		
	Total Contract Value	[insert amount]		
	Procuring Entity's Name Address Tel / Fax <u>e-mail</u>			
	Brief description with justifications of the similarity compared to the Procuring Entity's requirements	[state justification in support of its similarity compared to the proposed works]		
3.3	Average annual construction turnover [ITT Sub Clause 15.1(a)] <i>[[total certified payments received for contracts in progress or completed under public sector for a period as stated under ITT Sub Clause 15.1(a), using rate of exchange at the end of the period reported]]</i>			



	Year	Currency	Amount	
			Taka or Equivalent Taka	
3.4	Liquid assets available to meet the construction cash flow [ITT Sub Clause 15.1(b)]			
	No	Source of Financing	Amount Available	
In order to confirm the above statements the JV Partners shall submit , as applicable, the documents mentioned in ITT Sub Clause 32.1(d)				
3.5	Contact Details [ITT Sub Clause 32.1 (h)]			
	Name, address, and other contact details of JV Partner's Bankers and other Procuring Entity(s) that may provide references, if contacted by this Procuring Entity			
3.6	Qualifications and experience of key technical and administrative personnel proposed for Contract administration and management [ITT Sub Clause 32.1(f)]			
	Name	Position	Years of General Experience	Years of Specific Experience
<i>[JV Partners to complete details of as many personnel as are applicable. Each personnel listed above should complete the Personnel Information (Form PW3.A-5)]</i>				
3.7	Major Construction Equipment proposed to carry out the Contract [ITT Sub Clause 32.1(g)]			
	Item of Equipment	Condition (new, good, average, poor)	Owned, leased or to be purchased (state owner, lessor or seller)	
<i>[Tenderer to list details of each item of major construction equipment, as applicable]</i>				

Subcontractor Information (Form PW3A-4)



[This Form should be completed by each Subcontractor, preferably on its Letter-Head Pad]

Invitation for Tender No: [IFT No]
 Tender Package No [Package No]
 Lot No. (when applicable) [Lot No]

1. Eligibility Information of the Subcontractor [ITT Clauses 5 & 29]	
1.1	Nationality of Individual or country of Registration
1.2	Subcontractor's legal title
1.3	Subcontractor's registered address
1.4	Subcontractor's legal status <i>[complete the relevant box]</i>
	Proprietorship
	Partnership
	Limited Liability Concern
	Government-owned Enterprise
	Other (please describe)
1.5	Subcontractor's year of registration
1.6	Subcontractor's authorised representative details
	Name
	Address
	Telephone / Fax numbers
	e-mail address
1.7	Subcontractor to attach copies of the following original documents
	All documents to the extent relevant to ITT Clause 5 and 29 in support of its qualifications
The following two information are applicable for national Subcontractors	
1.8	Subcontractor's Value Added Tax Registration (VAT) Number
1.9	Subcontractor's Tax Identification Number (TIN)
[The foreign Subcontractors, in accordance with ITT sub Clause 5.1, shall provide evidence by a written declaration to that effect to demonstrate that it meets the criterion]	
2. Key Activity(ies) for which it is intended to be Subcontracted [ITT Sub Clause 19.1]	
2.1	Elements of Activity
	Brief description of Activity



2.2	List of Similar Contracts in which the proposed Subcontractor had been engaged	
	Name of Contract and Year of Execution	
	Value of Contract	
	Name of Procuring Entity	
	Contact Person and contact details	
	Type of Work performed	



Personnel Information (Form PW3A-5)

[This Form should be completed for each person proposed by the Tenderer in Form PW3A-2 & PW3A-3, where applicable]

Invitation for Tender No:	[IFT No]
Tender Package No	[Package No]
Lot No. (when applicable)	[Lot No]

A. Proposed Position (tick the relevant box)			
<input type="checkbox"/> Construction Project Manager	<input type="checkbox"/> Prime Candidate	<input type="checkbox"/> Alternative Candidate	
<input type="checkbox"/> Key Personnel	<input type="checkbox"/> Prime Candidate	<input type="checkbox"/> Alternative Candidate	
B. Personal Data			
Name			
Date of Birth			
Years overall experience			
National ID Number			
Years of employment with the Tenderer			
Professional Qualifications:			
1.			
C. Present Employment <i>[to be completed only if not employed by the Tenderer]</i>			
Name of Procuring Entity (working under):			
Address of Procuring Entity (working under):			
Present Job Title:			
Years with present Procuring Entity:			
Tel No:	Fax No:	e-mail address:	
Contact <i>[manager/personnel officer]</i> :			
D. Professional Experience			
Summarise professional experience over the past twenty years, in reverse chronological order. Indicate particular technical and managerial experience relevant to the project.			
	From	To	Company / Project / Position / Relevant technical and management experience.
1			
2			

Bank Guarantee for Tender Security (Form PW3A-6)



[This is the format for the Tender Security to be issued by any scheduled Bank of Bangladesh in accordance with ITT Clause 35 & 36]

Invitation for Tender No: _____

Date: _____

Tender Package No: _____

Lot No (when applicable): _____

To: _____

[Name and address of the Procuring Entity]

TENDER GUARANTEE No: [insert number]

We have been informed that [name of Tenderer] (hereinafter called "the Tenderer") intends to submit to you its Tender dated [date of Tender] (hereinafter called "the Tender") for the execution of the Works of [description of works] under the above Invitation for Tenders (hereinafter called "the IFT").

Furthermore, we understand that, according to your conditions, the Tender must be supported by a Bank Guarantee for Tender Security.

At the request of the Tenderer, we [name of Bank] hereby irrevocably unconditionally undertake to pay you, without cavil or argument, any sum or sums not exceeding in total an amount of Tk. [insert amount in figures and words] upon receipt by us of your first written demand accompanied by a written statement that the Tenderer is in breach of its obligation(s) under the Tender conditions, because the Tenderer:

- a. has withdrawn its Tender after opening of Tenders but within the validity of the Tender Security; or
- b. refused to accept the Notification of Award (NOA) within the period as stated under ITT; or
- c. failed to furnish Performance Security within the period stipulated in the NOA; or
- d. refused to sign the Contract Agreement by the time specified in the NOA; or
- e. did not accept the correction of the Tender price following the correction of the arithmetic errors as stated under ITT 58.1.

This guarantee will expire

- (a) if the Tenderer is the successful Tenderer, upon our receipt of a copy of the Contract Agreement signed by the Tenderer or a copy of the Performance Security issued to you in accordance with the ITT; or
- (b) if the Tenderer is not the successful Tenderer, twenty-eight (28) days after the expiration of the Tenderer's Tender Validity period, being [date of expiration of the Tender Validity plus twenty-eight (28) days].

Consequently, we must receive at the above-mentioned office any demand for payment under this guarantee on or before that date.

Signature

Signature

Letter of Commitment for Bank's Undertaking for Line of Credit (Form PW3A-7)

[This is the format for the Credit Line to be issued by any scheduled Bank of Bangladesh in accordance with ITT Clause 32.1(d)]



Invitation for Tender No:

Date:

Tender Package No:

Lot No (*when applicable*):

To:

[Name and address of the Procuring Entity]

CREDIT COMMITMENT No: [insert number]

We have been informed that *[name of Tenderer]* (hereinafter called "the Tenderer") intends to submit to you its Tender (hereinafter called "the Tender") for the execution of the Works of *[description of works]* under the above Invitation for Tenders (hereinafter called "the IFT").

Furthermore, we understand that, according to your conditions, the Tenderer's Financial Capacity i.e., Liquid Asset must be substantiated by a Letter of Commitment of Bank's Undertaking for Line of Credit.

At the request of, and arrangement with, the Tenderer, we *[name and address of the Bank]* do hereby agree and undertake that *[name and address of the Tenderer]* will be provided by us with a revolving line of credit, in case awarded the Contract, for execution of the Works viz. *[insert name of works]*, for an amount not less than BDT *[in figure]* (*in words*) for the sole purpose of the execution of the above Contract. This Revolving Line of Credit will be maintained by us until issuance of "Taking-Over Certificate" by the Procuring Entity.

In witness whereof, authorised representative of the Bank has hereunto signed and sealed this Letter of Commitment.

Signature

Signature

Notification of Award (Form PW3A-8)



Contract No:
To:
[Name of Contractor]

Date:

This is to notify you that your Tender dated [insert date] for the execution of the Works for [name of project/Contract] for the Contract Price of Tk. [state amount in figures and in words], as corrected and modified in accordance with the Instructions to Tenderers, has been approved by [name of Procuring Entity].

You are thus requested to take following actions:

- i. accept in writing the Notification of Award within seven (7) working days of its issuance in accordance with ITT Clause 67.
- ii. furnish a Performance Security in the form as specified and in the amount of Tk. [state amount in figures and words], within fourteen (14) days of acceptance of this Notification of Award but not later than [specify date], in accordance with ITT Clause 68 & 69.
- iii. sign the Contract within twenty-eight (28) days of issuance of this Notification of Award but not later than [specify date], in accordance with ITT Clause 72.

You may proceed with the execution of the Works only upon completion of the above tasks. You may also please note that this Notification of Award shall constitute the formation of this Contract which shall become binding upon you.

We attach the draft Contract and all other documents for your perusal and signature.

Signed

Duly authorised to sign for and on behalf of
[name of Procuring Entity]

Date:



Contract Agreement (Form PW3A-9)

THIS AGREEMENT made the [day] day of [month][year] between [name and address of Procuring Entity] (hereinafter called "the Procuring Entity") of the one part and [name and address of Contractor] (hereinafter called "the Contractor") of the other part:

WHEREAS the Procuring Entity invited Tenders for certain works, viz., [brief description of works] and has accepted a Tender by the Contractor for the execution of those works in the sum of Taka [Contract Price in figures and in words] (hereinafter called "the Contract Price").

NOW THIS AGREEMENT WITNESSED AS FOLLOWS:

1. In this Agreement words and expressions shall have the same meanings as are respectively assigned to them in the General Conditions of Contract hereafter referred to.
2. The documents forming the Contract shall be interpreted in the following order of priority:
 - (a) the signed Contract Agreement
 - (b) the Notification of Award
 - (c) the completed Tender and the Appendix to the Tender
 - (d) the Particular Conditions of Contract
 - (e) the General Conditions of Contract
 - (f) the Technical Specifications
 - (g) the General Specifications
 - (h) the Drawings
 - (i) the priced BOQ and the Schedules
 - (j) any other document listed in the **PCC** forming part of the Contract.
3. In consideration of the payments to be made by the Procuring Entity to the Contractor as hereinafter mentioned, the Contractor hereby covenants with the Procuring Entity to execute and complete the works and to remedy any defects therein in conformity in all respects with the provisions of the Contract.
4. The Procuring Entity hereby covenants to pay the Contractor in consideration of the execution and completion of the works and the remedying of defects therein, the Contract Price or such other sum as may become payable under the provisions of the Contract at the times and in the manner prescribed by the Contract.

IN WITNESS whereof the parties hereto have caused this Agreement to be executed in accordance with the laws of Bangladesh on the day, month and year first written above.

For the Procuring Entity For the Contractor

Signature

Name

National ID No.

Title

In the presence of Name

Address

Bank Guarantee for Performance Security (Form PW3A-10)



[This is the format for the Performance Security to be issued by any scheduled Bank of Bangladesh in accordance with ITT Clause 68, 69, 70 & 71]

Contract No: [insert reference number]

Date: [insert date]

To:

[insert Name and address of Procuring
Entity]

PERFORMANCE GUARANTEE No: [insert number]

We have been informed that [name of Contractor] (hereinafter called "the Contractor") has undertaken, pursuant to Contract No [insert reference number of Contract] dated [insert date of Contract] (hereinafter called "the Contract"), the execution of works [description of works] under the Contract.

Furthermore, we understand that, according to your conditions, the Contract must be supported by a Bank Guarantee for Performance Security.

At the request of the Contractor, we [name of Bank] hereby irrevocably unconditionally undertake to pay you, without cavil or argument, any sum or sums not exceeding in total an amount of Tk. [insert amount in figures and in words] upon receipt by us of your first written demand accompanied by a written statement that the Contractor is in breach of its obligation(s) under the Contract conditions, without you needing to prove or show grounds or reasons for your demand of the sum specified therein.

This guarantee is valid until [date of validity of guarantee], consequently, we must receive at the above-mentioned office any demand for payment under this guarantee on or before that date.

Signature

Signature



Bank Guarantee for Advance Payment (Form PW3A-11)

[This is the format for the Advance Payment Guarantee to be issued by any scheduled Bank of Bangladesh in accordance with GCC Clause 73]

Contract No: [insert reference number]

Date: [insert date]

To:

[insert Name and address of the Procuring
Entity]

ADVANCE PAYMENT GUARANTEE No: [insert number]

We have been informed that [name of Contractor] (hereinafter called “the Contractor”) has undertaken, pursuant to Contract No [insert reference number of Contract] dated [insert date of Contract] (hereinafter called “the Contract”), the execution of works [description of works] under the Contract.

Furthermore, we understand that, according to your Conditions of Contract under GCC Clause 73, the Advance Payment on Contract must be supported by a Bank Guarantee.

At the request of the Contractor, we [insert name of Bank] hereby irrevocably unconditionally undertake to pay you, without cavil or argument, any sum or sums not exceeding in total an amount of Tk. [insert amount in figures and in words] upon receipt by us of your first written demand accompanied by a written statement that the Contractor is in breach of its obligation(s) under the Contract conditions, without you needing to prove or show grounds or reasons for your demand of the sum specified therein.

We further agree that no change, addition or other modification of the terms of the Contract to be performed, or of any of the Contract documents which may be made between the Procuring Entity and the Contractor, shall in any way release us from any liability under this guarantee, and we hereby waive notice of any such change, addition or modification.

This guarantee is valid until [insert date of validity of guarantee], consequently, we must receive at the above-mentioned office any demand for payment under this guarantee on or before that date.

Signature

Signature



Bank Guarantee for Retention Money Security (Form PW3A-12)

[This is the format for the Retention Money Guarantee to be issued by any scheduled Bank of Bangladesh in accordance with GCC Clause 70]

Demand Guarantee

[Bank's Name, and Address of Issuing Branch or Office]

Beneficiary: [insert Name and Address of the Procuring Entity]

Date: [insert date]

RETENTION MONEY GUARANTEE No.: [insert number]

We have been informed that [insert name of Contractor] (hereinafter called "the Contractor") has entered into Contract Number [insert reference number of the Contract] dated [insert date] with you, for the execution of [insert name of Contract and brief description of Works] (hereinafter called "the Contract").

Furthermore, we understand that, according to the conditions of the Contract, when the Taking-Over Certificate has been issued for the Works and the first half of the Retention Money has been certified for payment, payment of Tk. [insert the amount of the second half of the Retention Money] which becomes due after the Defects Liability Period has passed and certified in the form of Defects Correction Certificate, is to be made against a Retention Money Guarantee.

At the request of the Contractor, we [insert name of Bank] hereby irrevocably unconditionally undertake to pay you any sum or sums not exceeding in total an amount of Tk. [insert amount in figures] (Taka [insert amount in words]) upon receipt by us of your first demand in writing accompanied by a written statement stating that the Contractor is in breach of its obligation under the Contract because the Contractor failed to properly correct the defects duly notified in respect of the Works.

It is a condition for any claim and payment under this guarantee to be made that the payment of the second half of the Retention Money referred to above must have been received by the Contractor on its account number [insert A/C no] at [name and address of Bank].

This guarantee is valid until [insert the date of validity of Guarantee that being twenty-eight (28) days beyond the Defects Liability Period]. Consequently, we must receive at the above-mentioned office any demand for payment under this guarantee on or before that date.

Signature

Signature



Section 6. Bill of Quantities

IT SHALL BE SEPARATE VOLUME CONTAINING FORM PW3A-1b and BOQ

Guidance Notes on the Bill of Quantities

Objectives

The objectives of the Bill of Quantities (BOQ) are;

- (a) to provide sufficient information on the quantities of Works to be performed to enable Tenders to be prepared efficiently and accurately; and
- (b) when a Contract has been entered into, to provide a priced BOQ for use in the periodic valuation of Works executed.

In order to attain these objectives, the items in the BOQ should be grouped into sections to distinguish between those parts of the Works that by nature, location, access, timing, or any other special characteristics may give rise to different methods of construction, phasing of the Works, or considerations of cost. General items common to all parts of the Works may be grouped as a separate section in the BOQ. Consistent with these requirements, the layout and content of the BOQ should be as simple and brief as possible. Quantities should be computed net from the Drawings, unless directed otherwise in the Contract, and no allowance should be made for bulking, shrinkage, or waste. Quantities should be rounded up or down where appropriate and spurious accuracy should be avoided.

The quantities given in the BOQ are estimated and provisional, and are given to provide a common basis for Tendering. The basis of payment will be the actual quantities of work ordered and carried out, as measured by the Contractor and verified by the Project Manager and valued at the rates or prices quoted in the priced BOQ, where applicable, and otherwise at such rates or prices as the Project Manager may fix within the terms and conditions of the Contract.

The method of measurements of completed works for payment shall be based on metric system unless otherwise unavoidable.

A sample format has been suggested.



Unit Rates and Price

All unit rates and prices quoted by the Tenderers against each basic item or activity shall include the Tenderer's profit, overheads, VAT and all other charges including corresponding incidental service charges and premiums for banking and insurances, as applicable and, thus forth the total Tender Price quoted by the Tenderers.

Daywork Schedule

A Daywork Schedule is commonly used in contracts where the likely incidence of unforeseen work cannot be covered by definitive descriptions and approximate quantities in the BOQ. A Daywork Schedule should therefore be included only if the probability of unforeseen work, outside the items included in the BOQ, is high. To facilitate checking by the Procuring Entity of the realism of rates quoted by the Tenderers, the Daywork Schedule should normally comprise the following:

- (a) a list of the various classes of labour, materials, and construction plant for which basic Daywork unit rates or prices are to be quoted by the Tenderer, together with a statement of the conditions under which the Contractor will be paid for work executed on a Daywork basis.
- (b) quantities for each item of Daywork, to be priced or quoted by each Tenderer at Daywork rates as Tender.

If a Daywork Schedule is to be included **at all** in the Tender Document, it shall include nominal quantities against the items most likely to be used and the unit rates or prices quoted by the Tenderer shall remain invariable whatever the quantities ordered.

A sample format of the Schedule has been suggested.

Provisional Sums

A general provision for physical contingencies (quantity overruns) or for meeting other essential expenditures may be made by including a provisional sum in the Summary BOQ. Similarly, a contingency allowance for possible price increases should be provided as a provisional sum in the Summary BOQ. The inclusion of such provisional sums often facilitates budgetary approval by avoiding the need to request periodic supplementary approvals as the future need arise.

A sample format has been suggested.

Correction of Errors

If in preparing BOQ of its Tender, the Tenderer has made errors in the unit rates or prices or the total price, and wishes to correct such errors prior to submission of its Tender, it may do so, but shall ensure that each correction of error is properly initialled by the authorised person of the Tenderer and that a statement shall be made as to the total number of such corrections made, at the end of the priced BOQ.

The Procuring Entity shall ensure that the following note is added at the end of each page of the BOQ.

"This BOQ contains [*state number*] corrections duly initialled and signed by the authorised person of the Tenderer".

THIS GUIDANCE NOTES FOR PREPARING A BILL OF QUANTITIES ARE INTENDED ONLY AS INFORMATION FOR THE PROCURING ENTITY OR THE PERSON DRAFTING THE TENDER DOCUMENT. THIS SHOULD NOT BE INCLUDED IN THE FINAL DOCUMENT



Bill of Quantities

Name of Works: **RENOVATION OF CRUDE OIL STORAGE TANK NO. T-6101C**

IFT No.: **ER/DEV (M)-40(1)/2022**

Item no.	Description of Item	Unit	Quantity	Unit Rate		Amount
				In figures	In words	In figures
1	2	3	4	5	6=5	7=4x5
<u>N.B.: SUPPLY OF GAS FOR CUTTING AND WELDING ROD IS INCLUDED FOR EACH ITEM.</u>						
<i>to be quoted and filled in by the Tenderer</i>						
01.	<p>CLEANING: Cleaning the shell inside (3' from bottom), roof upper & lower deck, wind girder, shell near wind girder or any other part of tank at any height and location for cleaning the hard sludge, heavy rust and scales including removing the debris, etc. from tank to a safe distance not less than 500 ft from dyke. Arrangement of all necessary de-scaling/cleaning tools and equipments like chipping hammer, scrapper, power brush, wire brush and necessary scaffolds are to be arranged by the Contractor.</p>	Sft	25000			
02.	<p>SEAL SYSTEM:</p>					
2.1	<p>SEAL REMOVAL: Removal/opening the floating roof seal (Approx. length 625 ft) from rim plate including removal of all fittings, clamping bars, flappers, nuts and bolts, foam blocks using appropriate tools and attachments and safe storing of seal and its components under the safe custody of contractor for reuse as per direction of ERL authority. Any ancillary and fixture/attachment need for safe opening to be made and arranged by the contractor. Any loss or damage due to contractor's fault must be made good or replenished by the contractor.</p>	LS	LS			
2.2	<p>HOLD DOWN PLATE: Repair/fabrication of hold down plate of size 400 mm x 375 mm with 2.3 mm thick MS or galvanized plate or flat bar as per existing sample. The job includes cutting, sizing, making holes, grinding & fixing of 460 mm x 170 mm x 50 mm (Th.) foam with suitable adhesive. Supply of foam & adhesive included.</p>	No	100			
2.3	<p>SEAL CLAMPING BAR: Repair/fabrication of seal clamping bar of size 395 mm x 50 mm x 4.5 mm. The job includes cutting, sizing, making holes & grinding.</p>	No	200			
2.4	<p>SEAL FIXING ANGLE: Removal, Repair/fabrication & refitting of seal fixing angle by 50 mm x 50 mm x 6 mm MS angle including bending the angle to match with the rim plate. The job includes fitting, tack welding and making holes for fixing seal as per drawing/existing one. Supply of MS angle included.</p>	Ft	630			
2.5	<p>SQUARE NECK BOLT: Supply of M10 mm x 40 mm (L) round headed square neck bolts and nuts as per original sample.</p>	No	500			
2.6	<p>FLAPPER CLAMP: Removal, repair/fabrication & refitting of flapper clamp at the circumferential edge of floating roof with supply of pin, split pin for each clamp. The job includes cutting, sizing, fitting, welding & grinding.</p>	No	300			
2.7	<p>FLAPPER: Repair/ fabrication of weather protection flappers of size 610 mm x 525 mm with 2 mm thick MS or galvanized sheet & protective plate of size 80 mm x 610 mm with 2</p>	No	300			



	mm thick brass sheet as per existing samples. The job includes cutting, sizing, making holes, stiffening groove, bending, fixing attachments etc. Supply of Galvanized sheet and necessary bolts & nuts included.				
2.8	SPLIT PIN WITH WASHER: Supply of split pin with washer of Ø5 mm x 20 mm (L).	No	320		
2.9	EARTHING CABLE: Supply of earthing cable with double bolt & nut with spring washer and fixing with brass plate and flapper. The job includes cutting, sizing, grinding & fitting of brass plate as per drawing/ instruction of ERL authority.	No	64		
03.	BOTTOM & ANNULAR: Removal of existing old plates of different thickness from the tank bottom & annular including any doubler of higher thickness by grinding/carbon arc gouging/gas cutting whatever applicable as per existing safety rule of ERL at a definite dimension not below 6' x 8'. Carrying of old/rejected plates from tank site to the ERL scrap yard and stacking the same at a pre selected place as advised by the Development/Store Officer. Carrying of new MS plate of thickness 5.00 mm to 12.00 mm of different dimensions from ERL store yard to the work site at the contractor's cost. Sizing of steel plates at a required measurement for bottom of the tank, lifting of MS plates at a height of 48' (approx.) where necessary, fitting, aligning, tack welding the steel plates; finally welding the plates with multiple pass arc welding as per API Standard 650. Mobilization of all machineries, equipments, ancillaries to the work site and fabrication of metallic walkway if needed are to be done by the contractor. Necessary supports, attachments, scaffolds, push cart, truck needed to carry out the job are to be arranged by the contractor.				
3.1	BOTTOM PLATE: Partial removal & fabrication of bottom plate of tank by MS plate of thickness not over 8 mm. this work includes gouging, grinding, lifting old plate and re-welding. N.B. the volume of work can be varied between 0% to 100% in accordance with the instruction provided by Inspection department of ERL. The volume of work will be confirmed on the basis of Engineering inspection performed before the starting of RENOVATION works.	MT	183		
3.2	ANNULAR PLATE: N.B. the volume of work can be varied between 0% to 100% in accordance with the instruction provided by Inspection department of ERL. The volume of work will be confirmed on the basis of Engineering inspection performed before the starting of RENOVATION works. This condition will be applicable for all kinds of works listed below related to annular plate replacement. (a-h)				
3.2(a)	PAD PLATE WITH SHELL: Marking, gas cutting, grinding of MS pad plates of size 12 mm (T) x 360 mm x 360 mm and to fix the same with multiple pass arc welding on different sections of the shell plate.	No	62		
3.2(b)	'H' BEAM ON PAD PLATE: Marking, gas cutting, grinding of MS 'H' beam (brackets) of dimension 300 mm x 300 mm x 15 mm (T) and to fix the same on the pad plate with multiple pass Arc welding to lift the tank shell to required height, to take out old annular plates and to insert new annular plates. After replacing the annular plate 'H' beam (brackets)	No	62		



	shall be removed from pad plates by gas cutting/grinding and the surface of the pad plate shall have to be made smooth. Supply of 'H' beam included.				
3.2(c)	SEPARATION OF FILLET WELD: Separation of fillet weld between annular plate and shell along the circumference of the tank by carbon arc gouging in and outside of the shell. Any pits due to corrosion or gouging shall be built up and grinded flush to make ready the shell bottom for welding with new annular plate. Supply of arc gouging machine along with carbon gouging holder, rod and air compressor included.	Ft	1260		
3.2(d)	STOPPER PLATE: Marking, sizing, cutting of stopper plates of 3" x 4" x 8 mm size and fixing with the annular plate by welding for positioning the shell and after complete welding the shell with annular plate, the stopper plates should be gouged out and the welding spots should be grinded flush for smooth surface.	No	800		
3.2(e)	HYDRAULIC JACK: Supply, fixing of 50 Tons capacity pump operated hydraulic jacks, lifting the tank shell to make minimum gap of 50 mm with annular plate. To unload the jack, the lifting and lower of jacks shall be done as per direction/decision of EIC and according to the suggestion of the ISHI IRON WORK which is available with Development Section.	No. of Location	62		
3.2(f)	ANNULAR PLATE: Removal of old annular plates and marking, sizing the new annular plate, preparing the edges of the annular plates by grinding allowing the butt clearance for welding, sizing of backing strip, tack welding on one side of the annular plate according to drawing then laying, positioning, aligning of annular plates as per direction and welding the same.	MT	16		
3.2(g)	REINFORCEMENT CHANNEL: Sizing of reinforcement channel to a required size of 150 mm x 75 mm x 6.5 mm x 2 M (L) including grinding the two ends and fixing the same with new annular plate and tank shell by arc welding and finally removal of reinforcement channels by grinding after completion of annular plate replacement work. Supply of Required channel included.	No	186		
3.2(h)	WELDING: Welding of shell to annular plate inside & outside using low hydrogen electrode as per instruction.	Ft	1260		
3.3	DRAW OFF SUMP: Removal of existing draw off sump of size Ø 1220 mm x 600 mm and fabrication of the same with 12/10 mm thick MS plate including collar and reinforcement plate at the bottom of the sump. After repair of mat sump to be placed at the proper position.	No	02		
3.4	PATCH, PAD PLATE: Patch work on roof, shell or any other location of tank including sizing the plates by gas cutting, lifting in position, grinding flush, welding by lap joint with 5 mm to 8 mm thick MS Plates as per instruction. Size of patch work is variable as per requirement. Fabricating, fixing of pad plate of size Ø 500/600 mm x 12 mm (Th.) under the deck post or any other location including sizing the plate, corner shaping and placing properly and welding the same. Any scaffold if needed to be arranged by the Contractor.	No	80		
04.	SHELL:				
4.1	HATCH OPENING & RE-WELDING:				



	The shell of the tank is to be cut at a dimension of 2.2 M x 0.6 M at a height of 0.7 M (approx.) with proper reinforcing supports both horizontally and vertically to keep the shell in its original shape and position. After completion of repair job the same cut off plate to be re-fixed in the same place & welded. The weld joint should pass both dye penetration & X-ray test.	No	01			
4.2	SHELL CLADDING: Shell patch work with 6mm plate of width approx. 300 mm at the bottom part of shell, cleaning scrapping, and welding (Arc welding) related with cladding is included.	Sft	350			
4.3	PITS BUILD UP: Build up of corroded pits at any position & height of tank by Arc-welding and surface of the buildup pits are to be grinded flush. Any scaffold needed is to be arranged by the contractor.	No	4000			
4.4	WELD JOINTS BUILD UP: Build up of existing corroded welding joints by Arc welding and surface of the buildup weld joints are to be grinded flush. Any scaffold needed is to be arranged by the contractor.	Ft	3000			
05.	ROOF:					
5.1	PONTOON UPPER & LOWER DECK: Removal of old MS plate from pontoon upper & lower deck of the tank (as required) by grinding, gas cutting whatever applicable of thickness not over 5.00 mm including any reinforcement plate of higher thickness. Removed old plates to be disposed off or to be stored at a pre selected place as decided by ERL authority. Carrying of new MS Plates of thickness 5.00 mm from ERL Store yard to the work site. Sizing of MS plates at a required measurement for pontoon upper deck of the tank including lifting of MS plates at a height of 48' (approx.) where necessary. Fitting, aligning, tack welding and finally welding with multiple pass Arc welding. Necessary attachments, scaffolds, truck, push cart, supports etc. are to be arranged by the contractor.					
5.1(a)	PONTOON UPPER DECK: Partial repair/replacement of pontoon upper deck by using MS Plates of thickness 5.00 mm. This work includes cleaning, scrapping, gouging, grinding and re-welding.	MT	48			
5.1(b)	PONTOON LOWER DECK: Partial repair/replacement of pontoon lower deck by using MS Plates of thickness 5.00 mm. This work includes cleaning, scrapping, gouging, grinding and re-welding.	MT	24			
5.2	PONTOON STRUCTURE: Repair/replacement of pontoon structure by gas cutting, grinding the damaged/deformed/corroded structure. Sizing, fitting, fixing the same by fabricating the members then finally welding. Any scaffold, attachment needed to be arranged by the contractor. Supply of necessary MS angle and channel included	MT	02			
5.3	FOAM DAM: Removal, re-installation/replacement of foam dam by 5.0 mm thick MS plate. The job includes removal of foam dam by gouging or gas cutting and replacing/refitting the same, finally welding. Slotting of specific size for water drainage is included. Supply of MS angle included	Sft	500			
5.4	RIM PLATE: Replacement of damaged rim plate by 5.00 mm thick MS Plates. The job includes removal of old plates by grinding, gas cutting as per requirement, carrying the	Sft	1000			



	same to the scrap yard and carrying the new plates from store-yard to the work site. Sizing, bending of MS plates at a radius of 29.40M to match with the curvature of rim. Necessary attachments, back strip where necessary & making scaffolds as per requirement of job included. Finally fitting, fixing and welding the same as per direction of ERL authority.				
5.5	NOZZLE/FITTINGS:				
5.5(a)	EMERGENCY DRAIN: Repair/replacement of emergency drain assembly with provision for water sealing by Ø 10" bucket (L-200 mm) at the lower end of Ø 6" drain pipe with necessary gussets, reinforcement plate.	No	04		
5.5(b) (i)	LEG POST LIFTING: Lifting of deck post for removing existing bottom plate, pad plate, spreading new bottom plate, fixing new pad plate & repair/replacement of deck post and casing. Supply of 50 Tons capacity pump operated hydraulic jacks, arrangement of supporting attachments and other necessary materials for lifting roof are included.	No	232		
5.5(b) (ii)	DECK POST REPAIR/REPLACEMENT: Repair/replacement of deck post by Ø 3" MS pipe providing lifting lug on the leg top and formation of notch at the bottom, making sleeve for fixing pin, fitting, machining including lifting of deck post etc. Supply of pin, split pin, ring gasket is included.	No	58		
5.5(b) (iii)	DECK POST CASING REPAIR/REPLACEMENT: Repair/replacement of deck post casing by Ø 4" MS pipe with necessary gussets and reinforcement plate at the top of lower and upper deck of pontoon, making hole (Ø 42 mm) for leg fixing including lifting of deck post.	No	58		
5.5(c)	ROOF DRAIN SUMP: Repair/replacement of roof drain centre sump of Ø 915 mm x 340 mm x 9.5 mm by bending MS plate with collar, wire netting cover with frame and Ø 6" nozzle.	No	01		
5.5(d)	BREATHER VALVE NOZZLE: Removal, re-installation or replacement of Ø 12" breather valve nozzle with reinforcement plate, flange & rib plate as per drawing or sample. The job includes cutting, sizing, fixing with reinforcement plate, aligning and finally welding.	No	02		
5.5(e)	GAUGE HATCH NOZZLE WITH COVER: Supply /repair/replacement of Ø 8" gauge hatch nozzle with cover & hinge. Rubber gasket included.	No	04		
5.5(f)(i)	PONTOON MANHOLE: Removal, re-installation or replacement of Ø 508 mm pontoon manhole by fabricating the same with MS pipe or by bending MS Plate of required thickness to pipe shape including fabrication of cover, handle & stopper. The job includes cutting, sizing, bending, fixing, aligning and finally welding.	No	10		
5.5(f)(i)	RUBBER GASKET : Supply of rubber gasket on pontoon manhole. As per sample provided by ERL	Ft	150		
5.5(g)	FLOAT CHAMBER: Repair/replacement of Ø 508 mm float chamber (length 1190 mm) with reinforcement plate & cover as per existing measurement. The job includes fabrication of Cylindrical barrel by 6 mm thick MS plate, making hole of required size in float chamber wall & bottom plate and fabrication of cover plate with flange, guide rod, handle etc.	No	01		
5.5(h)	PURGING/ VENTING POINT:				



	Replacement/installation of Ø 3/4" purging/venting points including fixing of guard valve, nipple & threaded cap.	No	02		
5.5(i)	AUTO VENT: Removal of existing corroded Auto Vent and fabrication of Ø 8" casing pipe (L-970 mm) with reinforcement plate, Ø 2.5" stand pipe (L-3.2 M), Ø 3" sleeve pipe & fabrication of cover with attachments. Supply of 2 nos. brass ring (Th. 3 mm), 3 nos. steel ring (Th. 3/6 mm), 3 nos. Ø 8" brass wire mesh, neoprene ring gasket & washer are included.	No	02		
5.5(j)	ROOF MANHOLE: Removal, re-installation or replacement of Ø 762 mm roof manhole by fabricating the same with MS pipe or by bending MS Plate of required thickness to pipe shape, making flange & top cover by machining and drilling for bolt holes. The job includes cutting, sizing, bending, machining, drilling, fixing with reinforcement plate, aligning and finally welding.	No	01		
5.5(k)(i)	HINGE PIN: Repair/ replacement, re-installation of hinge pin,	LS	LS		
5.5(k)(ii)	BOTH END THREADED ROD: Supply, fabrication, repair of M12 mm x 730 mm both end threaded rod of rolling ladder steps. Supply of nuts & washers are included.	No	20		
5.5(k)(iii)	ROLLING LADDER STEPS: Removal of the steps from rolling ladder by hacksaw cutting, grinding, gas cutting whatever applicable and fabrication, refitting in position, welding the same.	No	20		
5.5(k)(iv)	ROLLING LADDER RAIL: Supporting leg, rail, base of rolling ladder by fabricating, machining, welding etc.	LS	LS		
5.5(k)(v)	ROLLING LADDER WHEEL: Servicing of Ø 16" Rolling ladder wheel.	No	2		
5.5(l)	WIND GIRDER RAILING: Repair/Replacement of railing along the outer edge of wind girder by the following members:- i) MS pipe Ø 42.4 x 3.2 t or MS Angle 2" x 2" x ¼" top horizontal hand rail ii) MS flat bar 2" x ¼" iii) MS Angle 2" x 2" x ¼" x 3' (H) Vertical member The job includes Supply and fabrication of MS flat bar 2" x ¼" from MS plate of larger dimension & bending of top hand rail.	Ft	200		
5.6	SHELL NOZZLE				
5.6(a)	PURGING NOZZLE: Ø 4" purging nozzle with reinforcement plate. Marking, fixing, fitting and welding must be complied with the direction of ERL authority.	No	2		
5.6(b)	ROOF DRAIN NOZZLE: Ø 6" roof drain nozzle with reinforcement plate. Marking, fixing, fitting and welding must be complied with the direction of ERL authority.	No	1		
06.	GAUGE POLE:				
6.1	INSTALLATION OF NEW GAUGE POLE: Installation of new Ø 8" gauge pole of length 16 M, Ø 3" thermo-well of length 16 M, fitting in position with supports, datum plate & top cover with flange, hole making as required, Ø 24" casing pipe with top plate of size 960 mm x 780 mm x 9 mm, including supply of 2 nos. CS shaft with brass sleeve, Rubber & brass slide plate of size 1000 mm x 630 mm x 6 mm.	No	01		



6.2	EXISTING GAUGE POLE REPLACEMENT: Removal of Ø 8" gauge pole (Length 16 M) of the tank including cutting the Ø 8" pipe, top cover and datum plate including Ø 24" casing pipe by chisel and hammer, hacksaw & grinding whatever applicable with necessary supports, lifting the same, carrying to scrap yard and fabrication of Ø 8" gauge pole, Ø 24" casing, hole making as required, lifting by crane/scaffold, fitting in position with supports, datum plate & top cover including flange all complete as per direction of ERL authority.	No	01			
07.	PIPELINE: Carrying the new CS pipe from ERL store to work site, lifting, laying in position on supports, sizing the pipe and removal of existing old pipes and carrying the same to ERL scrap yard. Beveling, grinding, leveling, aligning, fitting and finally welding by multiple pass Arc welding. The weld joints are to be test passed by dye penetration or hydro-test.					
7.1	RECEPTION LINE: Replacement of Ø 16" reception line including wrapping of dyke portion (approx. 33 Ft).	Ft	170			
7.2(a)	FOAM LINE: Replacement of Ø 6" foam line including wrapping of dyke portion (approx. 66 Ft).	Ft	350			
7.2(b)	FOAM RING: Replacement of Ø 4" foam distribution ring at a height of 1 M from bottom including bending the pipes by hydraulic jack & bender as required curvature to match with the tank shell & making provision for flanged joints (16 nos. flange), drain points. Including foam ring support. Supply of MS angle and C channel for support making included	Ft	320			
7.2(c)	FOAM RISER: Replacement of Ø 3" foam riser including supports with shell. Necessary scaffolds are to be arranged by the contractor. Supply of necessary MS angle, bolt and nut included.	Ft	120			
7.2(d)	FOAM BOX: Removal, repair/replacement/servicing & re-fixing of foam boxes.	No	6			
7.3	UNIT FEED LINE: Replacement of Ø 8" unit feed line including wrapping of dyke portion (approx. 33 Ft).	Ft	270			
7.4	SLOP LINE: Replacement of Ø 4" slop line including wrapping of dyke portion (approx. 33 Ft).	Ft	270			
7.5	ROOF DRAIN LINE: Replacement of Ø 6" roof drain line including servicing & refitting of 8 nos. swivel joint & expansion joints. The job includes necessary support, pad plate making and flanged joints preparation. Supply of MS angle and C channel included.	Ft	170			
7.6	PURGING LINE: Replacement of Ø 4" purging line including 2 nos. flange & fabrication of 2 nos. 90° bend.	Ft	50			
7.7	MS SUPPORT: Supply and Fabrication of MS support by MS angle, channel etc. including sizing, welding & fitting on RCC foundation & with shell plate of the tank by welding as per direction. MS angle, MS channel will be supplied and carrying of materials should be done by Contractor.	No	35			
7.8	RCC SUPPORT: Construction of RCC support for Ø 16"/12"/8"/6"/ 4"					



	line including single brick flat soling, 3" CC work, base and column with a 10 mm thick anchor plate at the top. The job includes supply of MS rod, 3/4" down graded picked Jhama brick chips, cement & local coarse sand (salt free) of FM 1.5.	Cft	400		
08.	WIND GIRDER:				
8.1	WIND GIRDER REPLACEMENT: Replacement of wind girder by 8 mm thick MS plate. The job includes removal of wind girder by grinding, gas cutting and fitting, fixing and welding the same as per direction of ERL authority. Necessary attachments, back strip where necessary & making scaffolds as per requirement of job are included.	Sft	450		
8.2	HOLE MAKING IN WIND GIRDER: Making holes in wind girder 12 mm to 15 mm dia by gas cutting & finishing by filing as per direction of ERL authority.	No	500		
09.	STAIRWAY:				
9.1	STAIRCASE STEPS: Removal of the steps from stair case by hacksaw cutting, grinding, gas cutting whatever applicable and fabrication, refitting in position, welding the same.	No	20		
9.2	HANDRAIL: Replacement of hand rail of stair case. The job includes removal, bending of MS angle, fitting in position & welding the same.	Ft	30		
9.3	VERTICAL ROD Replacement of vertical rod, The job includes removal of corroded part of vertical rod and replace it by new one, supply of MS rod carried by Contractor	No	20		
10	SAND BLASTING & PAINTING:				
10.1	SAND BLASTING: Cleaning the surface of the tank bottom weld joints (6" width), annular plate, top side of upper deck, shell bottom inside (2 Ft from bottom), roof drain line, purging line, purging sump, shell bottom outside including annular (1 Ft from bottom), emergency drain pot, wind girder, flapper, hold down plate, foam dam etc. by sand blasting to get the surface smooth and rust free for painting. The rate to be quoted by the contractor including laborers, sand blasting machine and diesel/electric engine operated compressor of 100 Cfm at 7 Bar capacity (minimum), blasting technician, painters etc. Supply of required sand F.M. 1.8 to 2 (no sea sand allowed) sand, drying, straining and painting equipment etc. all to be arranged by the contractor. The used sand after blasting to be removed from dyke upto a distance not less than 500 Ft. Required diesel or electrical power only for operating air compressor will be supplied by ERL free of cost. Scaffolds needed to carry out blasting are to be arranged by the contractor. (Any low classed and category air compressor will not be accepted).	Sft	50000		
10.2	EPOXY PAINTING: Providing 02 or more coats Coal tar Epoxy/Epoxy synthetic enamel paint over 01 coat of epoxy red oxide primer on the sand blasted surface of tank bottom weld joints (6" width), annular plate, top side of upper deck, shell bottom inside (2 Ft from bottom), roof drain line, purging line, purging sump, shell bottom outside including annular (1 Ft from bottom), emergency drain pot, wind girder, flapper, hold down plate, foam dam etc. by roller brush including cleaning the surface with cotton waste etc. all to be completed as per direction. All necessary painting equipment like roller brush, buckets	Sft	50000		



	etc., scaffold (if needed) to carry out painting and painter will be arranged by the contractor. Epoxy paint will be supplied by contractor. The quality of Epoxy paint will be checked by ERL authority				
10.3	NON EPOXY PAINTING: Providing 02 or more coats of non epoxy synthetic enamel paint over 01 coat of red oxide primer on non sand blasted surface like pontoon inside, railing, stairway, foam system, pipe lines etc. preparing the surface by wire brush, emery paper, cup brush, cotton waste etc. and cleaning the surface as per direction of ERL authority. All painting, cleaning equipment, scaffold (if needed) and painter to be arranged by the contractor. Required paint will be supplied by Contractor. The quality of synthetic paint will be checked by ERL authority.	Sft	75000		
11.	SEAL FIXING: Hole making (\varnothing 12 mm, 1080 x 3 nos.) in new seal envelope (Width-1.273 M, Length-217.69 M), joining open end of seal envelope by suitable adhesive approved by ERL authority and then placing, fitting, fixing the seal at its original position by clamping bars, nuts and bolts etc. The cushioning foam blocks and hold down plates should be assembled properly. Any damage due to contractor's fault to be compensated by him. Supply of required adhesive & other equipments are included.	LS	LS		
12.	EARTH WORK:				
12.1	DYKE CUTTING, EARTH EXCAVATION & BACK FILLING: Dyke cutting, earth excavation for replacing different pipe lines & making approach road inside and outside of the dyke to facilitate transportation of tank repair materials and off take scrap materials from tank to the outside. Remaking the dyke with excavated earth, filling in layers and leveling, compacting the same properly laying 6" thick layer of clay on dyke, leveling, watering etc. all complete as per direction and satisfaction of ERL authority.	Cft	8000		
13.	TANK GRADE (MAT, PAD) REPAIR:				
13.1	LOOSE SAND REMOVAL & BACK FILLING: The tank mat to be repaired after removal of bottom plate. Loose and oil soaked sand to be removed to a distance not less than 500 ft from the tank dyke area and back filling the soaked sand removed area with Juldia coarse sand and compacting the spreaded sand at 6" from 9" by height at layers up to required height including supply of sand. Supply of required sand is included. N.B. the volume of work can be varied between 0% to 100% in accordance with the instruction provided by Inspection department of ERL. The volume of work will be confirmed on the basis of Engineering inspection performed before the starting of RENOVATION works.	Cft	8000		
13.2	MACADAM: Supply and laying 50 mm down graded 1 st class brick chips to provide hard core/fill up the ditches in the tank mat and pad area by mixing the same with sand FM 1.2 in (2:1) (khoa:sand) proportion to achieve required compacted volume and screening chips, mixing, laying and spreading in 50 mm layers uniformly and compacting etc. All to be completed as per requirement and satisfaction of ERL authority. Supply of Brick chips and Sand included.	Cft	8500		



	<p>N.B. the volume of work can be varied between 0% to 100% in accordance with the instruction provided by Inspection department of ERL. The volume of work will be confirmed on the basis of Engineering inspection performed before the starting of RENOVATION works.</p>				
13.3	<p>BITUMINOUS CONCRETE: Providing premixed bituminous concrete to provide hard core/fill up the ditches in the tank mat and pad area with ¾" down graded 1st class brick chips premixed with 3 Kgs of bitumen with 1 Cft of brick chips including heating, mixing, laying in position compacting with hand rammer on a tack coat @ 7 Kgs of bitumen per 100 Sft of surface area. All complete as per direction and satisfaction of ERL authority. Bitumen of 80/100 grade to be used for the job. Supply of required concrete & bitumen is included.</p> <p>N.B. the volume of work can be varied between 0% to 100% in accordance with the instruction provided by Inspection department of ERL. The volume of work will be confirmed on the basis of Engineering inspection performed before the starting of RENOVATION works.</p>	Cft	900		
13.4	<p>BITUMINOUS SAND CARPETING: Providing premixed bituminous coarse sand at a thickness of 40 mm on a tack coat @ 7 Kgs of bitumen per 100 Sft of surface area on the back filled compacted and leveled area and any other required area of the tank bottom. 2.5 Kgs of bitumen to be premixed with 1 Cft of sand. The job includes supply of sand, bitumen, labourer, sundries fire wood etc. Bitumen of 80/100 grade to be used for the job. Supply of required sand & bitumen is included.</p> <p>N.B. the volume of work can be varied between 0% to 100% in accordance with the instruction provided by Inspection department of ERL. The volume of work will be confirmed on the basis of Engineering inspection performed before the starting of RENOVATION works.</p>	Sft	32000		
13.5	<p>BITUMINOUS SEAL COAT INCLUDING BITUMINOUS PAINTING: Providing bituminous seal coat ¾" compacted to ½" with Sylhet sand premixed with 2.5 Kgs of bitumen with 1 Cft of Sylhet sand including heating the bitumen, mixing with Sylhet sand, laying, compacting with hand rammer on a tack coat @ 7 Kgs of bitumen per 100 Sft of surface on tank pad. Providing painting with 8 Kgs of bitumen per 100 Sft of surface area uniformly including heating the bitumen upto 175^o - 188^o Celsius. Then the painted surface should be covered by spreading 6 Cft sand of 1.5 F.M. on 100 Sft surface area. All to be completed as per requirement and satisfaction of ERL authority. Bitumen of 80/100 grade to be used for the job. Supply of required sand & bitumen is included.</p> <p>N.B. the volume of work can be varied between 10% to 100% in accordance with the instruction provided by Inspection department of ERL. The volume of work will be confirmed on the basis of Engineering inspection performed before the starting of RENOVATION works.</p>	Sft	7500		
14.	<p>BOX-UP, CLEANING & PREPARATION OF ALL KINDS OF TESTS: Box-up of AGM, shell & roof manholes, cleanout door, blind up the shell nozzles etc. for hydro-test the tank.</p>				



	After successful hydro-test the manholes, cleanout door should be opened and the tank inside should be cleaned properly up to the satisfaction of ERL authority. The rate should include arrangement of buckets, brooms, spades and dusters etc. which are needed for cleaning the tank. The tank inside should be made dust, dirt, clay and water free. It includes making preparation of all kinds of tests.					
14.1	<p>MPT TEST: Performing MPT test with necessary equipments. All the preparation for test must be taken by contractor. Submission of successful report of MPT test must be handed over to concerned department of ERL. The Test procedure and Report must be accepted by ERL Authority.</p> <p>N.B. the volume of work can be varied between 0% to 100% in accordance with the instruction provided by Inspection department of ERL. The volume of work will be confirmed on the basis of Engineering inspection performed before the starting of RENOVATION works.</p>	Ft	1260			
14.2	<p>X-ray TEST: Performing X-ray at hatch and at any other position the ERL authority feels to be done. All kind of preparation must be taken by contractor. Submission of successful report of X-ray must be handed over to concerned department of ERL. The Test procedure and Report must be accepted by ERL Authority.</p>	Ft	20			
14.3	<p>TEST PREPARATION AND BOX UP: All type of preparation including cleaning, washing, scraping must be done by contractor. After completing all kind of test box-up of AGM, shell & roof manholes, cleanout door, blind up the shell nozzles etc. for hydro-test the tank. After successful hydro-test the manholes, cleanout door should be opened and the tank inside should be cleaned properly up to the satisfaction of ERL authority. The rate should include arrangement of buckets, brooms, spades and dusters etc. which are needed for cleaning the tank. The tank inside should be made dust, dirt, clay and water free.</p>	LS	LS			
Total						
(IN WORDS:)						



Section 7. General Specifications (GS)

A. MATERIALS TO BE SUPPLIED BY ERL: The following materials with mentioned specification will be supplied by Eastern Refinery Limited (ERL).

1. MS PLATES:

The supplied MS plates will be as follows:

Material: A 283 Gr. C/ A36/ JIS G 3106 SM 400B/ ABS Gr. A/ Q235B

Size:

- a) For sump, annular plate : 6000 mm x 1800 mm x 12 mm
- b) For bottom plate : 6000 mm x 1800 mm x 8 mm
- c) For rim plate, upper & lower deck : 6000 mm x 1800 mm x 5 mm

2. CS PIPES:

The supplied CS pipes will be as follows:

Specification: API 5L Gr.B, Sch-40, ERW, ANSI B 31.3 : For pipe above 2" dia
A 106 Gr B, Sch-80, Seamless, ANSI B 31.3 : For pipe below 2" dia & Shell nozzles

B. MATERIALS TO BE SUPPLIED BY CONTRACTOR: The following materials as per mentioned specification will be supplied by the appointed contractor.

1. WELDING ELECTRODE:

The required welding electrodes should be as follows:

Specification : Vortic Marine E6013

Size : 2.5 mm, 3.2 mm & 4.0 mm

Manufactured by Linde, Bangladesh. The supplied electrodes should be test passed by ERL.

Specification : Ferrocraft/Multicraft: E7016/ E7018 (Low Hydrogen Electrode)

Size : 2.5 mm, 3.2 mm & 4.0 mm

Manufactured by Linde, Bangladesh. The supplied electrodes should be test passed by ERL.

2. GAS CUTTING EQUIPMENT:

a) **FLASHBACK ARRESTOR:** Flashback arrestor should be murex. Saffire or equivalent & must be fitted on the cylinder head.

b) **GAS REGULATOR:** The gas cylinders should have proper regulator.

c) **GAS FOR CUTTING:** The supplied gas should be Oxygen & Acetylene/ LPG. Those should meet the standard.

d) **GAS CYLINDERS:** The oxygen & acetylene gas cylinders must be manufactured by Linde, Bangladesh.

3. MS ANGLES:

MS angles of different required sizes **will be supplied by Contractor**. Must be manufactured by **BSRM or equivalent manufacturer**. Any low classed material will not be accepted by ERL authority. The quality of MS structural material will be checked by ERL authority.



4. **PAINTS:**

Required paints (Epoxy enamel, Synthetic Enamel, Red oxide primer, Epoxy Red Oxide primer) will be supplied by Contractor. Must be manufactured by **BERGER paints Bangladesh Ltd. or equivalent manufacturer**. Any low classed paint will not be accepted by ERL authority. The quality of paints will be checked by ERL authority.

5. **WELDING MACHINE:**

Should be D.C. Welding Machine, 400-600 Amps, 380V, 3 Phase, 50 Hz.

6. **HYDRAULIC JACK:**

Pump operated Hydraulic Jack of 50 MT capacities each.

7. **SAND BLASTING MACHINE:**

Sand blasting equipment (complete) with bucket, compressed air reservoir and air compressor of capacity 100 Cfm at minimum 7 bar pressure.

8. **TEST EQUIPMENTS:**

All the necessary equipments, necessary test personel needed for MPT test and X-ray will be supplied by Contractor

9. **BITUMEN, SAND & CONCRETE:**

Bitumen: 80/100 grade bitumen is to be used for Mat & Pad repair.

Sand: FM 1.8 to 2 is to be used (no sea sand is allowed).

Concrete: 1st class brick chips.

10. **POWER SUPPLY PANEL:**

Power supply panels (2 nos.) containing the following accessories to be arranged by the contractor. Complete wiring of power supply panel shown in single line diagram (Drawing No.-ER/DEV (M)/40(1)/2022-5).

I. Main breaker:	MCCB, 400 Amps, 380 V AC, 3 pole	--- 01 No.
II. Breaker for Air compressor:	MCCB, 200A, 380V AC, 3 Pole	--- 01 No.
III. Breaker for welding machine:	MCCB, 63A, 380V AC, 3 Pole	--- 05 Nos.
IV. Breaker for grinding machine:	MCB, 16A, 220V AC, 2 Pole	--- 04 Nos.
V. Breaker for Transformer input:	MCCB, 25 A, 380 V AC, 2 Pole	--- 01 No.
VI. Breaker for Transformer output:	MCCB, 63 A, 220V AC, 2 Pole	--- 01 No.
VII. Breaker for lighting p/supply:	MCB, 10A, 220V AC, 2 Pole	--- 04 Nos.
VIII. Bus bar:	380V AC, 400 Amps	--- 03 Nos.
IX. Bus bar: (2 for 220V, 1 for neutral)	220V AC, 200 Amps	--- 03 Nos.
X. A meter (with 3 CT & one 3-phase selector switch):	0-300 Amps	--- 01 No.
XI. A voltmeter (with a 3-phase selector switch):	0-500 Amps	--- 01 No.
XII. Transformer:	15 KVA, 380/220V AC, 2 phase	--- 01 No.
XIII. Signal lamp for showing voltage existence:		--- 03 Nos.

11. **SCAFFOLDING, LIFTING, WORKING MATERIALS:**

Required scaffolding, lifting & working materials like wire rope, chain hoist, painting brush, roller, wedge, shim plate, key plate, blank nut, safety equipment, PSP, as required should be supplied by the contractor.



Section 8. Particular Specifications

1.0 SCOPE OF WORK:

Successful Tenderer will undertake renovation of 1 (one) **Crude Oil Storage Tank** having capacity of 32,000 cubic meter including cleaning, earth work, replacement of bottom, annular plate, roof, roof railing, wind girder, leg & leg casing, stairway, pipelines, tank mat, pad etc. and sandblasting, painting including attachments as required.

2.0 CIVIL WORKS:

The following civil works are to be done by the contractor.

2.1 DYKE CUTTING, EARTH EXCAVATION & BACK FILLING:

Dyke cutting for replacing pipe lines, making approach road & remaking the dyke with excavated earth, filling in layers, leveling & compacting the same properly. Laying 6" thick layer of clay on dyke, leveling, watering etc. Earth excavation for making trench to replace purging line & back filling the same after completion of work.

2.2 TANK GRADE (MAT, PAD) REPAIR:

2.2.1 LOOSE SAND REMOVAL & BACK FILLING: Loose and oil soaked sand to be removed from tank mat and back filling with Juldia coarse sand and compacting the spreaded sand at 6" from 9" by height at layers up to required height including supply of sand. **Supply** of required sand is included.

2.2.2 MACADAM: Supply and laying 50 mm down graded 1st class brick chips to provide hard core/fill up the ditches in the tank mat and pad area by mixing the same with sand FM 1.2 in (2:1) (khoa:sand) proportion to achieve required compacted volume and screening chips, mixing, laying and spreading in 50 mm layers uniformly and compacting etc. All to be completed as per requirement and satisfaction of ERL authority.

2.2.3 BITUMINOUS CONCRETE: Contractor shall provide premixed bituminous concrete to provide hard core/fill up the ditches in the tank mat and pad area with ¾" down graded 1st class brick chips premixed with 3 Kgs of bitumen with 1 Cft of brick chips including heating, mixing, laying in position compacting with hand rammer on a tack coat @ 7 Kgs of bitumen per 100 Sft of surface area. Bitumen of 80/100 grade is to be used for the job. **Supply** of required concrete & bitumen is included.

2.2.4 BITUMINOUS SAND CARPETING: Contractor shall provide premixed bituminous coarse sand at a thickness of 40 mm on a tack coat @ 7 Kg of bitumen per 100 Sft of surface area on the back filled compacted and leveled area and any other required area of the tank bottom. 2.5 Kgs of bitumen to be premixed with 1 Cft of sand. The job includes supply of sand, bitumen, labourer, sundries fire wood etc. Bitumen of 80/100 grade is to be used for the job. **Supply** of required sand & bitumen is included.

2.2.5 BITUMINOUS SEAL COAT INCLUDING BITUMINOUS PAINTING: Contractor shall provide bituminous seal coat ¾" compacted to ½" with Sylhet sand premixed with 2.5 Kgs of bitumen with 1 Cft of Sylhet sand including heating the bitumen, mixing with Sylhet sand, laying, compacting with hand rammer on a tack coat @ 7 Kgs of bitumen per 100 Sft of surface on tank pad. Providing painting with 8 Kgs of bitumen per 100 Sft of surface area uniformly including heating the bitumen upto 175^o-188^o Celsius. Then the painted surface should be covered by spreading 6 Cft sand of 1.5 F.M on 100 Sft surface area. Bitumen of 80/100 grade is to be used for the job. **Supply** of required sand & bitumen is included.



3.0 SAND BLASTING & PAINTING:

3.1 SAND BLASTING: Surface is to be cleaned by sand blasting before painting. Contractor shall supply sand blasting machine and diesel/electric engine operated compressor of 100 Cfm at 7 bar capacity (minimum), blasting technician, painters etc. Supply of required sand F.M. 1.8 to 2 (no sea sand allowed) sand, drying, straining and painting equipment etc. all to be arranged by the contractor. The used sand after blasting to be removed from dyke upto a distance not less than 500 Ft. required diesel or electricity only for operating air compressor will be supplied by ERL free of cost. Scaffolds needed to carry out blasting are to be arranged by the contractor. Any low classed and category air compressor will not be accepted. The following procedure should be maintained:

- i) Before blasting grind smooth, sharp edges of weld etc. and remove all oil, weld spatter and flux.
- ii) Blast cleans all steel surfaces and welds to be coated as required.
- iii) No blasted surfaces shall remain uncoated overnight in humid areas. If so, it should be blasted again.
- iv) If blast cleaning facilities are not possible then power tool cleaning, may be used, with the written approval of the Owner.

3.2 PAINTING: All site painting shall be done by the SUCCESSFUL TENDERER following procedure as detailed below :

- i) All paints to be applied to a surface should be free from moisture, oil, dust, grit or any other contaminant and discoloration.
- ii) Two or more coats to be done for having the required DFT.
- iii) Pipe lines crossing the dyke, roads culverts should be painted with Coal tar epoxy & then wrapped with suitable PVC/Plastic tape. Casing pipe should be provided whenever necessary.

The following areas on the tanks are to be painted as per specification:

- | | |
|--|---|
| a) 1. Top side of annular plate | : Two coats coaltar epoxy after sand blasting (Total DFT min. 150 Micron). |
| 2. Bottom 0.5 meter of shell | : Do. |
| 3. Weld joint of bottom plate (about 6" area) | : Do. |
| 4. Roof drain line | : Do. |
| 5. Shell outside (bottom 1') | : Do. |
| 6. Emergency drain pot | : Do. |
| b) Top side of upper deck, wind girder | : One coat epoxy red oxide and two coats epoxy enamel aluminum paint after sand blasting at damaged locations only. |
| c) Upper side of lower deck, under side of upper deck and pontoon inside | : One coat red oxide after cleaning as required. |
| d) Flapper | : One coat epoxy red oxide and two coats epoxy enamel aluminum paint after cleaning. |
| e) Rolling ladder & wind girder railing | : One coat red oxide and two coats yellow paint after proper surface preparation. |
| f) All pipelines | : One coat red oxide and two coats aluminum paint after proper surface preparation. |

g) Foam system

: One coat red oxide and two coats signal red after proper surface preparation (foam box-yellow).

h) Supports, stairway

: One coat red oxide and two coats bituminous black after proper surface preparation.





Section 9. Drawings

Sl. No.	Drawing no.	Description
1	ER/DEV (M)-40(1)/2022-1	Plot plan of ERL
2	ER/DEV (M)-40(1)/2022-2	Cross section of floating roof tank
3	ER/DEV (M)-40(1)/2022-3	Shell nozzle, manhole & reinforcing plate
4	ER/DEV (M)-40(1)/2022-4	Draw off sump, wind girder & roof manhole
5	ER/DEV (M)-40(1)/2022-5	Power supply panel

FORMAT

LOGO



[Insert Full Contact Details of the Procuring Entity]

Commencement of Works

Office Memo No:

Date:

To:

[Name of Contractor]
[Address]

Contract Reference:

Pursuant to GCC Sub Clause 39.1 of the above mentioned Contract Agreement, this is to notify you that the following precedent conditions have been duly fulfilled:

- (i) the Contract Agreement has been signed;
- (ii) the possession of the Site has been given; and
- (iii) the advance payment has been made *(delete if not appropriate)*.

You are therefore requested to:

1. Commence execution of the Works, in accordance with GCC Sub Clause 1.1(nn), within *(specify date)*;
2. Submit Insurance Policy Documents, in accordance with GCC Sub Clause 36.2, within *(specify date)*
3. Submit Programme of Works, in accordance with GCC Sub Clause 41.1, within *(specify date)*

Signed

Duly authorised to sign for and on behalf of
[name of Procuring Entity]

Date:

FORMAT

LOGO



[Insert Full Contact Details of the Procuring Entity]

CONTRACT AMENDMENT

Contract No.	
Amendment No.	
Approval Reference No.	

Contract No. [insert number/year] by and between the [insert Procuring Entity's name] and [insert Contractor's legal title] for the contract named [insert name of the Works and physical services] is amended as follows:

1. GCC Clause [insert clause no], is hereby revised as _____

2. GCC Clause [insert clause no], is hereby revised as _____

and so on .

The effective date of this Amendment is [insert effective date] or upon execution whichever is later.

ALL OTHER TERMS AND CONDITIONS OF THE ORIGINAL CONTRACT SHALL REMAIN IN FULL FORCE AND EFFECT

THIS AMENDMENT, consisting of [insert number] page(s) and [insert number] attachment(s), is executed by the persons signing below who warrant that they have the authority to execute this Amendment under the original Contract.

IN WITNESS WHEREOF, the Procuring Entity and the Contractor have signed this Amendment.

[Contractor's Authorized Signatory]

[Procuring Entity's Authorized Signatory]

Signature

Signature

Title

Date

Title

Date

FORMAT

LOGO

[Insert Full Contact Details of Issuing Authority]



Office Memo no: _____

Date: _____

COMPLETION CERTIFICATE

01	Procuring Entity Details		
	(a) Division	:	
	(b) Circle/Directorate	:	
	(c) Zone/Region	:	
	(d) Others (<i>specify</i>)	:	
02	Name of Works	:	
03	Contract No	:	
04	Contractor's Legal Title	:	
05	Contractor's Contact Details	:	
06	Contractor's Trade License/Enlistment/Registration Details	:	
07	Reference to NOA with Date	:	
08	Original Contract Price as in NOA	:	
09	Final Contract Price as Executed	:	
10	Original Contract Period		
	(a) Date of Commencement	:	
	(b) Date of Completion	:	
11	Actual Implementation Period		
	(a) Date of Actual Commencement	:	
	(b) Date of Actual Completion	:	
12	Days/Months Contract Period Extended	:	
13	Amount of Bonus for Early Completion	:	
14	Amount of LD for Delayed Completion	:	
15	Physical Progress in Percent (<i>in terms of value</i>)	:	
16	Financial Progress in Amount (<i>in terms of payment</i>)	:	
17	Special Note (<i>if any</i>)	:	

Certified that the Works under the Contract has been executed and completed in all respects in strict compliance with the provisions of the Contract including all plans, designs, drawings, specifications and all modifications thereof as per direction and satisfaction of the Project Manager/Engineer-in Charge/Other (*specify*). All defects in workmanship and materials reported during construction have been duly corrected.

Name and Signature of the Issuing Authority with Designation
please turn over

Details of Works Completed



Contractor: [insert legal title]		
No	Major Components of Works	Total Value (in Contract Currency)

Joint Venture [delete, if not appropriate]

Leading Partner: [insert legal title]		
No	Components/Activities [reference drawn to JV Partner Information]	Value (in Contract Currency)

Co-partner: [insert legal title]		
No	Components/Activities [reference drawn to JV Partner Information]	Value (in Contract Currency)

Co-partner: [insert legal title]		
No	Components/Activities [reference drawn to JV Partner Information]	Value (in Contract Currency)

Note: Figures shown must correspond to Total Value

Sub-contractor [delete, if not appropriate]

Named Sub-contractor: [insert legal title] [delete, if not appropriate]		
No	Components/Activities [reference drawn to Sub-contractor Information]	Value (in Contract Currency)

Nominated Sub-contractor: [insert legal title] [delete, if not appropriate]		
No	Components/Activities [reference drawn to PCC of Contract Document]	Value (in Contract Currency)

Name and Signature of the Issuing Authority with Designation

FORMAT



Invitation for Tenders (IFT)

*The **Invitation for Tenders (IFT)** is a copy of the standard format as appears on the website and used for published advertisement that provides relevant and essential information to help Tenderers to decide whether or not to participate in the particular Tender. This is provided in the Tender Document for information only. This should not be included in the FINAL DOCUMENT.*



Invitation for Tenders

[This is the website format and as used for published advertisement.
It is included in this document for information only]

GOVERNMENT OF THE PEOPLE'S REPUBLIC OF BANGLADESH					
1	Ministry/Division	< select >			V
2	Agency	< select >			V
3	Procuring Entity Name	< type in name >			
4	Procuring Entity Code	Not used at present			
5	Procuring Entity District	< select >			V
6	Invitation for	< select >	V	< select >	V
7	Invitation Ref No	< type in name >			
8	Date	< select >			V
KEY INFORMATION					
9	Procurement Method	< select >	V	< select >	V
FUNDING INFORMATION					
10	Budget and Source of Funds	< select >			V
11	Development Partners (if applicable)	< type in name >			
PARTICULAR INFORMATION					
12	Project / Programme Code (if applicable)	< use MOF code >			
13	Project / Programme Name (if applicable)	< use MOF name >			
14	Tender Package No.	< type in name >			
15	Tender Package Name	< type in name >			
16	Tender Publication Date	< select >	V		
17	Tender Last Selling Date <i>[up to the day prior to the day of Deadline for Submission]</i>	< select >	V		
		Date		Time	
18	Tender Closing Date and Time	< select >	V	< select >	V
19	Tender Opening Date and Time	< select >	V	< select >	V
20	Name & Address of the office(s)	Address			
	- Selling Tender Document (Principal)	< type in name >			
	- Selling Tender Document (Others)	< type in name >			
NO CONDITIONS APPLY FOR SALE, PURCHASE OR DISTRIBUTION OF TENDER DOCUMENTS					
21	- Receiving Tender Document	< type in name >			
	- Opening Tender Document	< type in name >			
	Place / Date / Time of Pre-Tender Meeting (Optional)	< type in name >			
		Date		Time	
		< select >	V	< select >	V
INFORMATION FOR TENDERER					
22	Brief Eligibility and Qualification of Tenderer	< type in name >			
23	Brief Description of Works	< type in name >			
24	Brief Description of Physical Services	< type in name >			
25	Price of Tender Document (Tk)	< type in price >			
	Lot No	Identification of Lot	Location	Tender Security Amount (Tk)	Completion Time in Weeks/Months
26	1	< type in name >	< type in name >	< type in >	< type in >
27	2	< type in name >	< type in name >	< type in >	< type in >
28	3	< type in name >	< type in name >	< type in >	< type in >
29	4	< type in name >	< type in name >	< type in >	< type in >
30	Name of Official Inviting Tender	< type in name >			
31	Designation of Official Inviting Tender	< type in name >			
32	Address of Official Inviting Tender	< type in name >			
33	Contact details of Official Inviting Tender	< Tel. No. >	< Fax No. >	< e-mail >	
34	The Procuring Entity reserves the right to reject all the Tenders or annul the Tender proceedings				

<select> : these fields are "pop-up" fields and the procuring entity will only have to select the correct name, address or date in order to complete the form. <type in name> : these fields are to be completed by typing in the relevant data.

Note: All italicized text (including footnotes) is for use in preparing this form and shall be deleted from the final product.

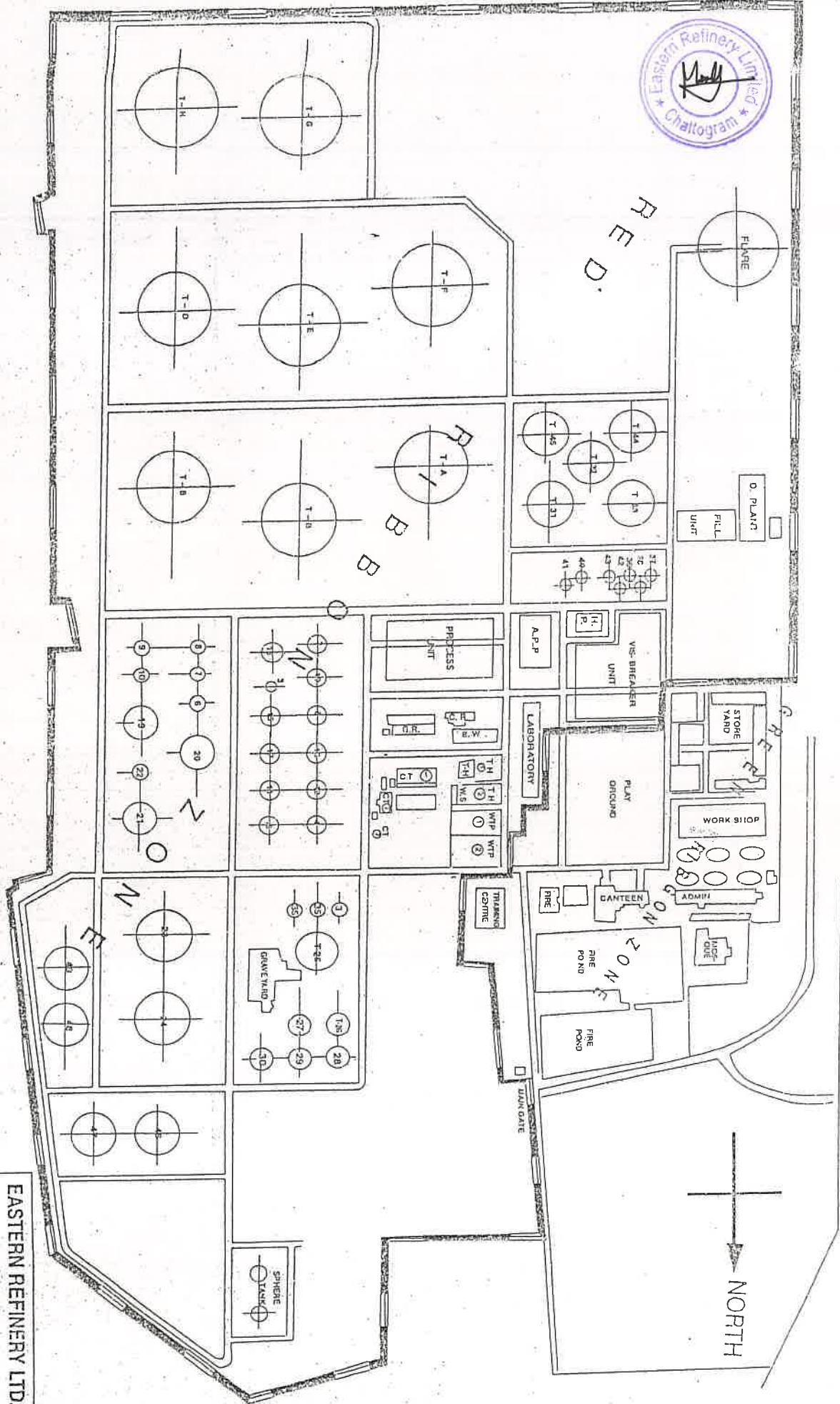

EASTERN REFINERY LTD.
 NORTH PATENGA, CHITTAGONG

PLOT PLAN

DRAWN BY: *[Signature]*
 CHECKED BY: *[Signature]*
 APPROVED BY: *[Signature]*

SCALE: _____
 REG. ENG. NO.: _____
 DRG. NO.: _____

ER/DEV(M)-40(1)/22-10

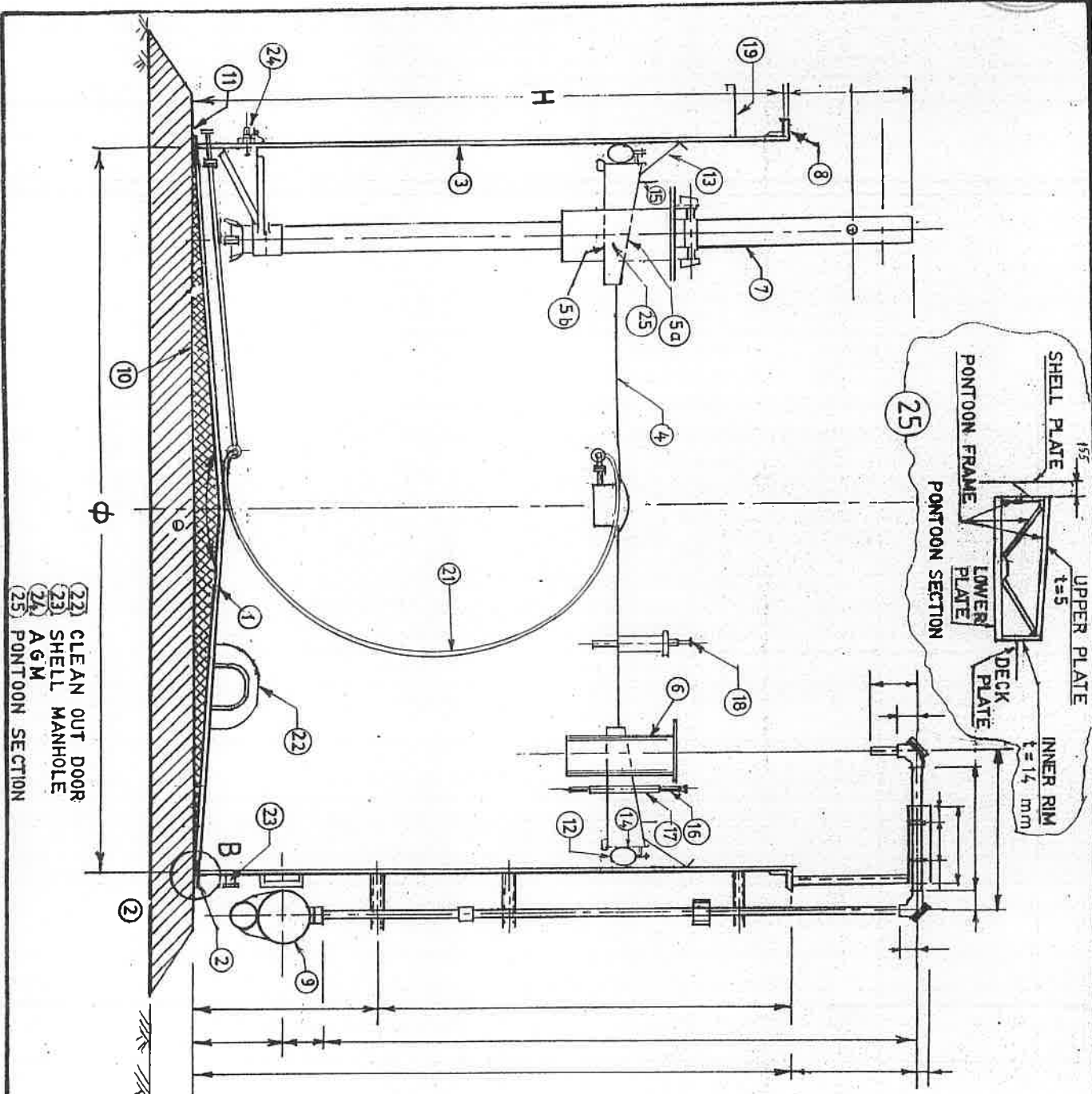

- (22) CLEAN OUT DOOR
- (23) SHELL MANHOLE
- (24) A G M
- (25) PONTOON SECTION

EASTERN REFINERY LTD	
NORTH PATENGA, CHITTAGONG.	
CROSS SECTION	
OF	
FLOATING ROOF TANK	
DRAWN BY: <i>[Signature]</i>	DATE:
CHECKED BY:	
APPROVED BY:	DRG. NO.

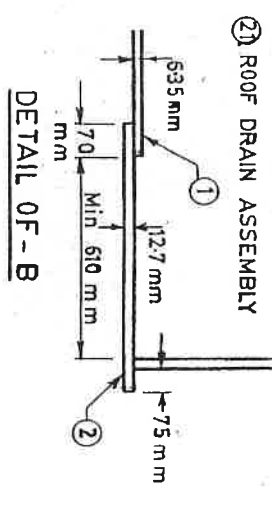

- (1) BOTTOM PLATE
- (2) BOTTOM ANNULAR PLATE
- (3) SHELL PLATE (4) ROOF SINGLE DECK
- (5a) PONTOON UPPER DECK
- (5b) PONTOON LOWER DECK
- (6) FLOAT CHAMBER
- (7) DIP GAUGE POLE
- (8) CURB ANGLE
- (9) DIAL GAUGE/SCALE RIDER
- (10) TANK MAT
- (11) TANK PAD
- (12) SEAL ASSEMBLY
- (13) WEATHER SHIELD/FLAPPER
- (14) RIM PLATE
- (15) FOAM DAM
- (16) DECK POST
- (17) DECK POST CASING
- (18) AUTO VENT
- (19) WIND GIRDER
- (21) ROOF DRAIN ASSEMBLY

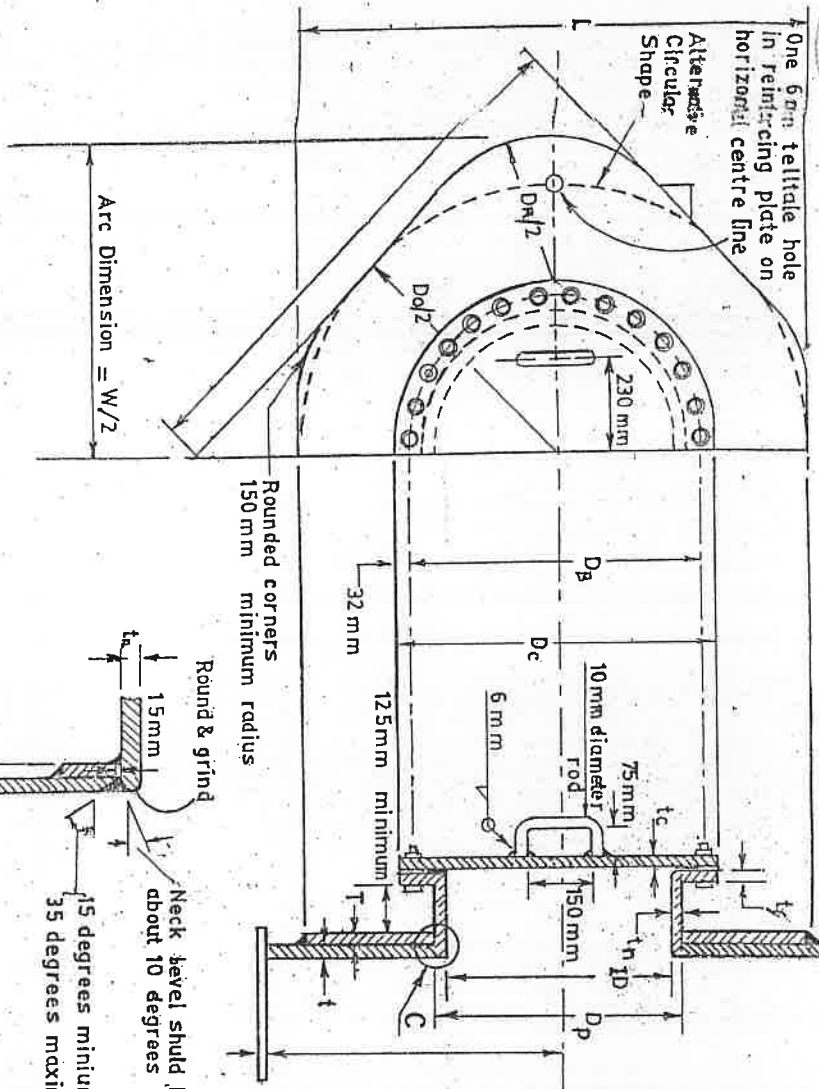

FIGURE : SHELL MANHOLE

DETAIL 'C'

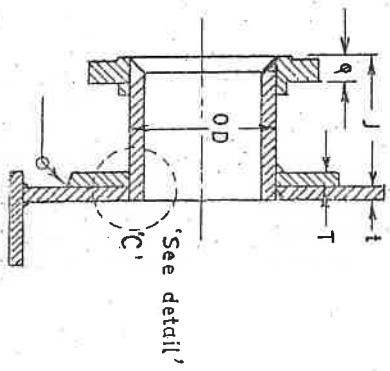

Figure: SHELL NOZZLE

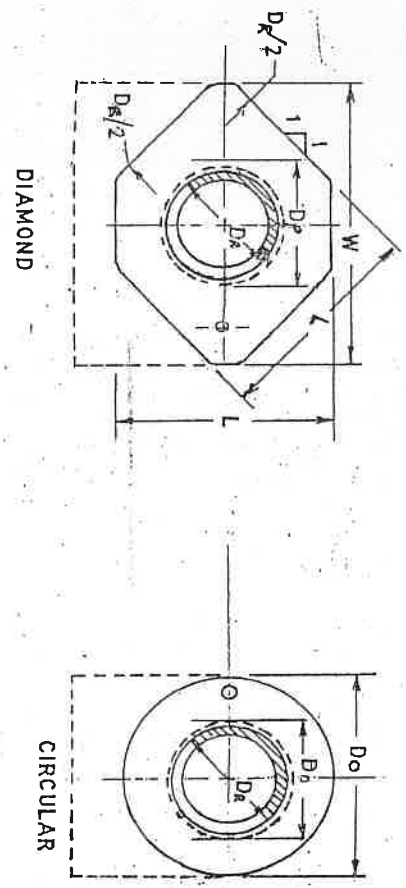

FIGURE : SHELL NOZZLE REINFORCING PLATE

EASTERN REFINERY LTD	
NORTH PATENGA, CHITTAGONG.	
DRAWING OF SHELL MANHOLE,	
SHELL NOZZLE & SHELL	
NOZZLE REINFORCING PLATE	
DRAWN BY: <i>[Signature]</i>	
CHECKED BY: <i>[Signature]</i>	
APPROVED BY:	DRAWING No.:

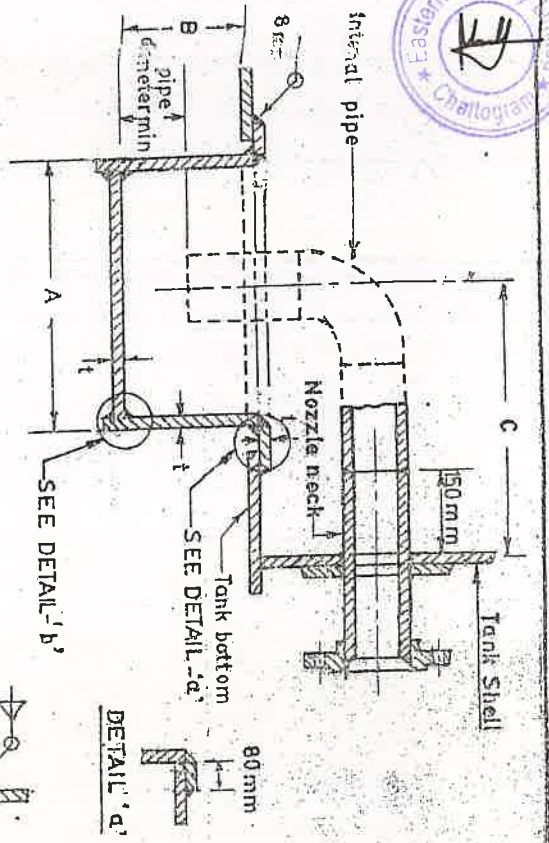
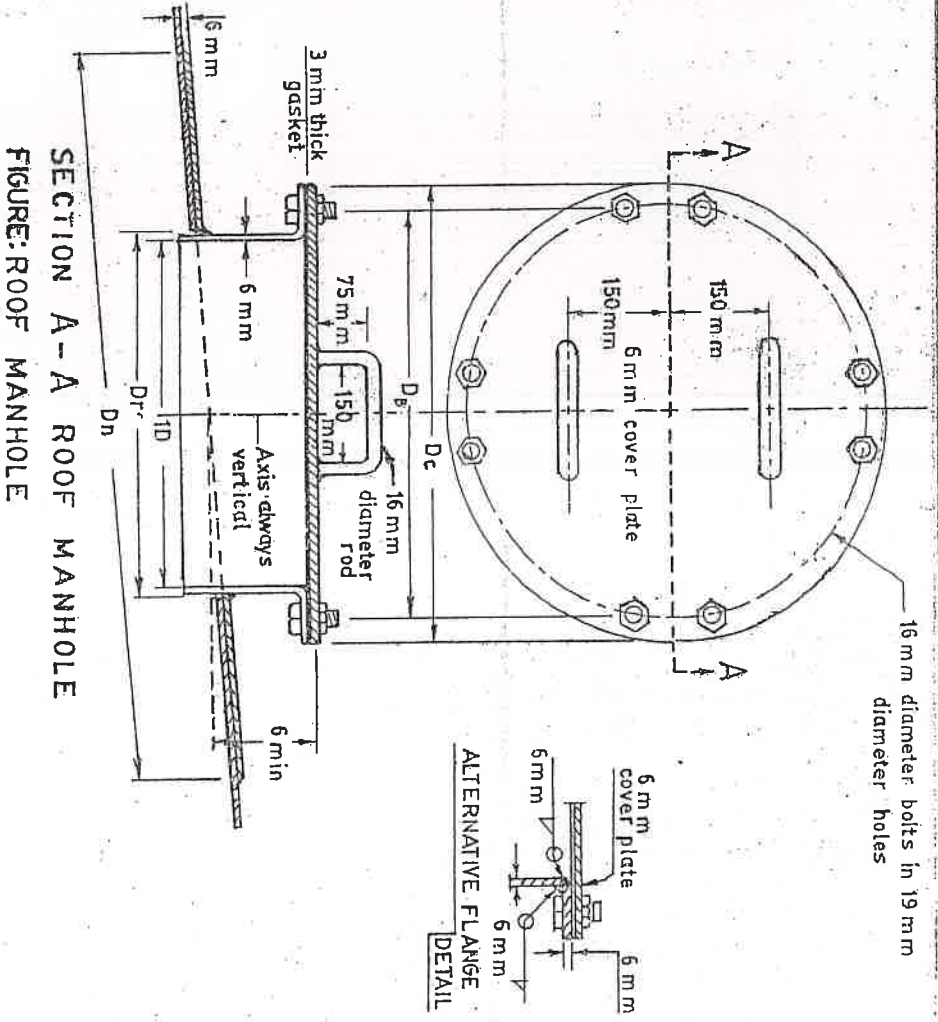
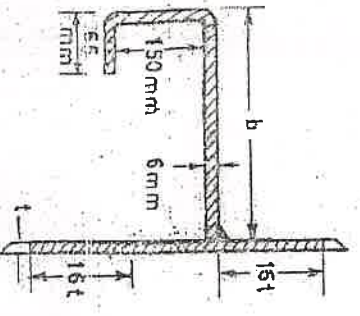
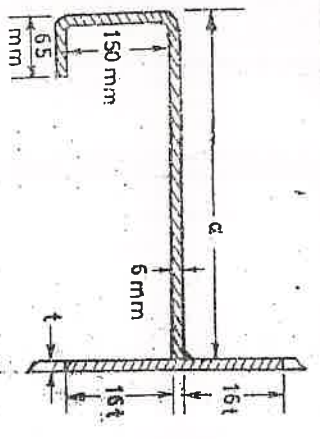
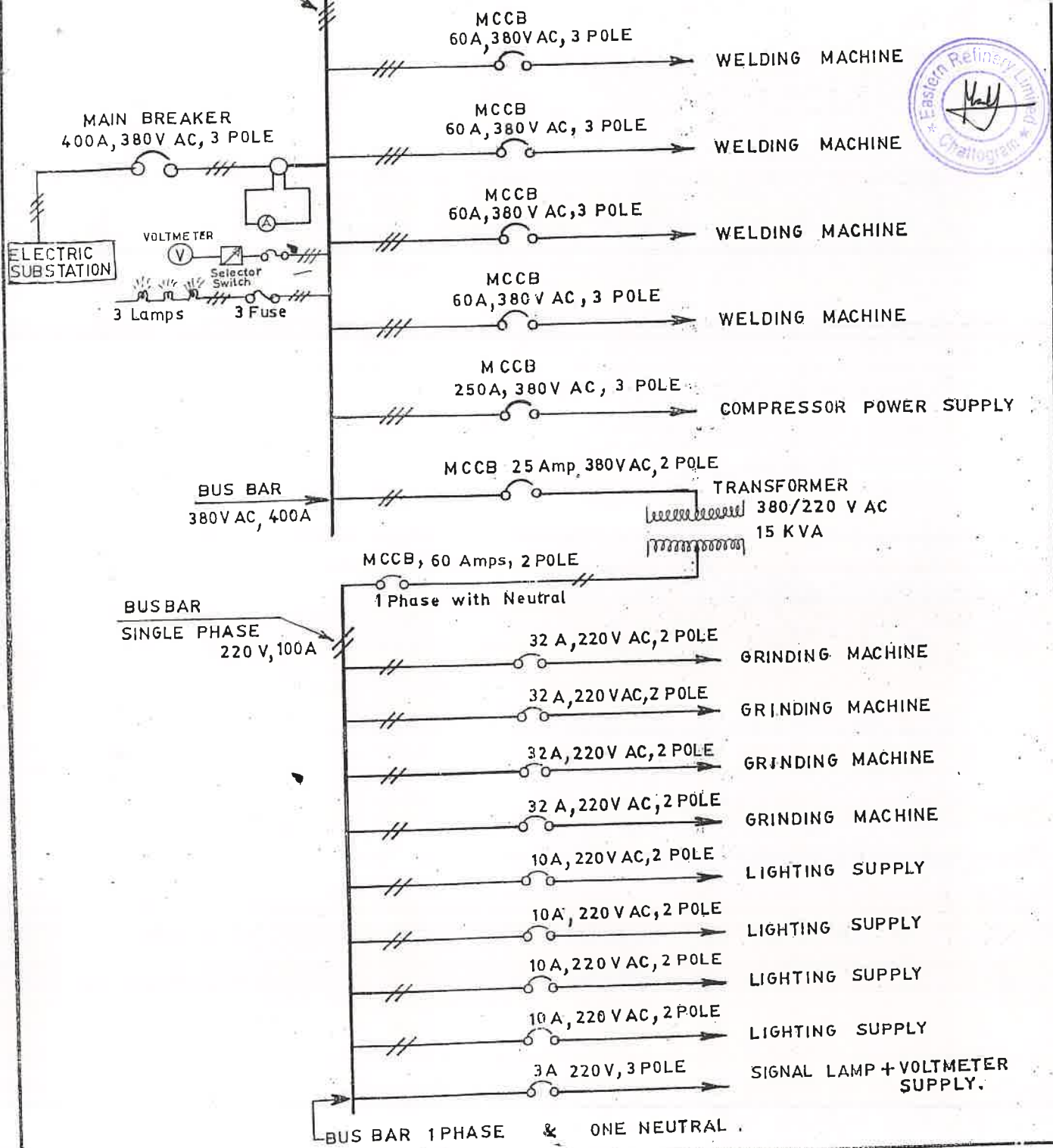

FIGURE: DRAW OFF SUMP



SECTION A-A ROOF MANHOLE
FIGURE: ROOF MANHOLE

EASTERN REFINERY LTD.	
NORTH PATENGA CHITTAGONG	
DRAWING OF DRAW OFF SUMP, WIND GIRDER & ROOF MANHOLE	
DESIGNED BY: <i>Atiqul Kabir</i>	
CHECKED BY: <i>Nizam</i>	
APPROVED BY:	
DRAWING No.	



EASTERN REFINERY LTD. North Patenga. Chittagong.	
FIG: POWER SUPPLY PANEL (SINGLE LINE DRAWING OF WIRING)	
Drawn By: <i>M. M. Islam</i>	Date:
Checked By: <i>Nizam</i>	
Approved By:	DRG. NO:

ER/DEV(M) - 40(1)/2022-5